

TURATI

COLLECTION



ALPINO, ESTANTE, NEXT STOP, MIND
THE GAP, INTERCHANGE, MEETING
POINT, TONELLA, PION

SANCAL 

TURATI
COLLECTION



SANCAL 

TURATI COLLECTION LLEGA PUNTUAL A SU CITA.

Hace dos años, en ruta por el maratónico Fuorisalone, **Esther** y **Elena Castaño-López** se apearon por error en una estación de la línea M3 que las dejó maravilladas. El color, la luz, la arquitectura y la atmósfera de **Turati** causaron en ellas un efecto casi epifánico, por lo que decidieron que tenían que hacer una colección inspirada en tan emblemático metro. Dicho y hecho.

Estudio Sancal se ha inspirado en esta estación para iniciar el viaje de presentación de los nuevos productos de la firma. Así, la escenografía y demás elementos que arropan a **Turati Collection** recrean fielmente algunos pasajes e inventan otros, siempre partiendo de la línea M3 como referente y con una paleta restringida al gris, amarillo y rojo.

Turati Collection es un homenaje a la modernidad de Milán y también a su conservadurismo, gracias al cual, la ciudad hace de lo moderno algo clásico.

TURATI COLLECTION ARRIVES ON TIME.

Two years ago, Sancal's creative combo, **Esther** and **Elena Castaño-López** made a wrong turn on the metro when thundering through Milan Design Week's Fuorisalone. They were hit by the atmosphere of Turati station and had an epiphany: this would provide the ideal backdrop for a new collection of products.

The firm's mise en scène for the **Turati Collection** faithfully recreates some aspects and invents others, always with the M3 line as a reference and colour palette restricted to grey, yellow and red.

The collection is a tribute to the modernity of Milan as well as its conservatism, a city of contemporary classics.

ALPINO 6 - 17



NEXT STOP 18 - 37



INTERCHANGE 38 - 43



ESTANTE 44 - 49



MEETING POINT 50 - 57



MIND THE GAP 58 - 63

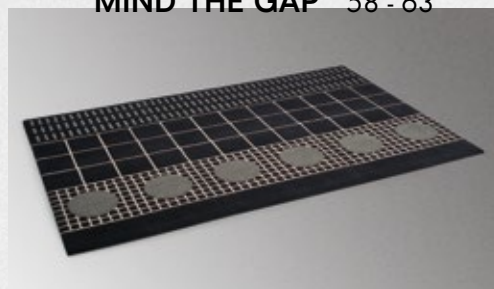

TONELLA 64 - 69



PION 70 - 75



COSAS 76 - 79

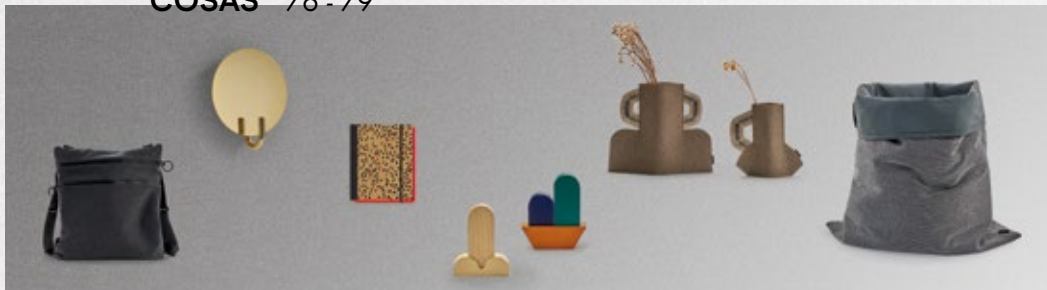

DESIGNERS

NICHETTO STUDIO

Luca Nichetto es uno de los diseñadores más reconocidos en el panorama internacional. Aunque inició su carrera profesional en 1999, trabajando para respetadas marcas como Foscarini, no fue hasta 2006 cuando creó su propio estudio de diseño en Venecia. En 2011 abrió una segunda sede en Estocolmo, su ciudad de adopción. Su personal visión del diseño está influida por ambas culturas, escandinava e italiana, que fusiona bajo un profundo conocimiento de los procesos industriales y artesanales.

Con **Turati** en el centro del brief, el diseñador italiano firma un set con un variado elenco de productos, dominando con acierto la unión entre diseño y función en esta primera colaboración con **Sancal**.



Luca Nichetto is one of the most renowned international designers. Although he started his career in 1999 working for acclaimed brands like Foscarini, in 2006 he founded his own multidisciplinary design studio in Venice. In 2011, Nichetto opened a second studio in Stockholm, Sweden. His personal take on design is influenced by both cultures; Scandinavian and Italian, being joined by a deep knowledge of craftsmanship and industrial processes.

Sancal asked him to take inspiration from the **Turati** metro station in Milan to create a complete set of products. The end result successfully combines form and function in his first collaboration with the marque.



RAFA GARCÍA

Rafa García forma parte del corazón creativo de **Sancal** y es el creador de alguna de las piezas más reconocidas de la firma. Sus diseños de líneas racionales y aspecto atemporal cautivan no sólo por sus formas, sino por el confort de su sentada, inherente en cada uno de ellos. Sus recientes diseños **Mousse**, **Deep**, **Obi** y **Tiptoe** se suman a las piezas más clásicas del catálogo como **Air**, **Eleva** o **Nido**.

Rafa sits at the creative heart of **Sancal** and is also the author of some of the firm's perennial products. His rational, timeless designs captivate not only for their shapes, but also for the comfort inherent in each of them. His latest creations include **Mousse**, **Deep**, **Obi** and **Tiptoe** following on from the best-sellers **Air**, **Eleva** or **Nido**.

MARIE-LOUISE ROSHOLM

Más de 30 años de experiencia en la industria de la moda y diseño de interiores avalan el trabajo de esta diseñadora textil, experta en la confección industrial de tejidos de punto. Su visión sostenible en la fabricación de tejidos aporta un valioso concepto a sus diseños y desarrollo de nuevos productos. En colaboración con **Luca Nichetto**, **Marie-Louise Rosholm** ha desarrollado **Zero**, un textil que revoluciona el actual concepto de la tapicería.



With more than 30 years of experience in the fashion and interior design industries, she is a textile expert. Her sustainable vision for textile manufacturing has informed her product development. In collaboration with **Luca Nichetto**, **Marie-Louise Rosholm** has developed **Zero** for **Sancal**, a revolutionary textile the likes of which have never been seen before.



JUAN IBÁÑEZ LAX

Diseñador gráfico y de producto, coordina la imagen corporativa de **Sancal**, participando directamente en la elaboración de escenografías, ilustraciones, catálogos y web. Después de la extensa familia de mesas y mesitas **Nudo**, con **Estante** nos propone un amplio y juguetón programa modular de almacenaje, tan versátil y alegre como lo es él.

Graphic and product designer, **Juan** coordinates the corporate image of **Sancal**, participating directly in the development of stand and shop design, illustrations, catalogues and the web. Following on from his extensive family of tables, **Nudo**, he presents an extensive and playful modular design, called **Estante** it is as versatile and cheerful as he is.

IONNA VAUTRIN

Tras su graduación en 2002 en la escuela de diseño de Nantes, **Ionna** trabajó en empresas de reconocido prestigio internacional. En 2011 recibió el Grand Prize de la creación que otorga la ciudad de París y fundó su propio estudio desde el que ha trabajado para editoras como: Industreal, Lexon, Wallpaper, Foscarini, Moustache o Bosa. En poco tiempo **Ionna** se ha convertido un valor seguro del nuevo diseño francés. Nos enamoramos de ella gracias a sus interesantes propuestas para Foscarini, aunque las mesitas **Pion** ocupan ahora un lugar central en nuestro corazón.



After graduating from the Nantes design school, **Ionna** worked with prestigious companies. She received the Grand Prize for a piece commissioned by the city of Paris in 2011 and went on to found her own studio – working with some of the sector's most important companies. In only a few years, **Ionna** has become a rising star in French design. The company fell in love with her interesting ideas for Foscarini, although the **Pion** tables are now the new favourites.



ESTUDIO SANCAL

El **Estudio Sancal** nació con la finalidad de dar soporte técnico a los diseñadores freelance con los que **Santiago Castaño** comenzó a trabajar a mediados de los años '80.

Esther y **Elena** han convertido este pequeño atelier en el corazón creativo de la empresa. Con las dosis justas de tesón y locura, lideran un talentoso equipo multidisciplinar para desarrollar los más variopintos proyectos; desde una campaña de publicidad a la escenografía de toda una colección o productos tan singulares como los **Perigallo**.

Estudio Sancal was born with the purpose of giving technical support to the freelance designers with whom **Santiago Castaño** began working in the mid-1980s.

Esther and **Elena** have turned this small atelier into the creative heart of the company. With the right doses of determination and madness, they lead a talented multidisciplinary team to develop the most varied of projects; from an advertising campaign to the scenography of a whole collection of products, some as unique as the **Perigallo**.



NOTE DESIGN STUDIO

Note tiene sede en Estocolmo. El estudio, fundado en 2008 por un equipo multidisciplinar, realiza proyectos de interiorismo, producto y gráfica. Como diseñadores de producto, sus trabajos para Le Chance, Menu, Zero o Punt entre otras destacadas marcas han tenido amplia repercusión. **La Isla** es su segunda colaboración tras la exitosa familia de asientos **Tonella**, que ahora se amplía con un puf en dos medidas.

Se presentan a sí mismos del siguiente modo: *“Notar algo y hacerse notar: nuestro nombre nombra aquello que perseguimos. Nos gusta prestar atención a aquello que nos rodea y tratar de crear piezas que hagan a los demás sentir lo mismo. Buscando aquello que es único en cada proyecto y enfatizándolo, conseguimos transformar valores y sensaciones en objetos y espacios táctiles”.*

Note is a Stockholm-based design studio founded in 2008 working within the fields of architecture; interior; product and graphic design as well as design strategy. Their pieces for Le Chance, Menu, Zero or Punt among other brands have become renowned worldwide. They have designed the **Tonella** family of seats – which now boasts a new range of poufs – and **La Isla**, a sofa for public spaces.

Their philosophy is to stand out from the crowd: *“To note something, to get noticed: we are named after what we try to achieve. We like to pay attention to our surroundings, and try to create things that make others do the same. By looking at what is unique in every project and emphasizing that, we transform non-material values into tactile objects and spaces.”*

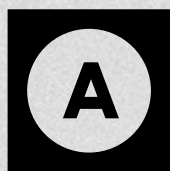

ALPINO

By RAFA GARCÍA

Conexión Natural.

Escapar a la naturaleza y disfrutar de sus fascinantes vistas para recargar energía es una de las más placenteras formas de desconexión de la rutina y el estrés diarios.

Rafa García y su bici a menudo se aventuran por bosques y montañas, lugares en los que se ha inspirado para su nueva creación, **Alpino**. Un sofá modular especialmente concebido para uso doméstico. Con este modelo el diseñador traslada la sensación de bienestar que experimenta cuando se encuentra al aire libre, esos sentimientos de libertad y calma que le invaden, y crea un reconfortante refugio para la intimidad del hogar.

Los suaves picos de las almohadas y la base de los respaldos se solapan entre sí para simular el perfil montañoso de las cordilleras alpinas. La altura del respaldo es uno de los elementos a destacar, pues recoge de manera natural la cabeza de quienes se dejan abrazar por sus mullidas almohadas. Su confort es tal, que resulta el compañero perfecto para no perder la concentración durante un maratónico maratón de series. Y los no teleadictos podrán dormir tras un largo paseo campestre o desparramarse a leer relajadamente el periódico.

Un diseño de apariencia serena y sencilla, no carente de complejidad constructiva por la peculiar forma de los brazos y la delgadez y suavidad de los respaldos.

De nuevo, **Rafa** ofrece múltiples soluciones para personalizar las composiciones en respuesta a las necesidades que marcan los diferentes espacios. Un brazo solapa que imita una manta dejada caer sobre sí mismo y un brazo recto. Cuatro tipos de puf con diferentes funciones: integrado dentro de la composición como un asiento sin respaldo, como ángulo para crear rincones, como terminal o, simplemente, como puf independiente. La modulación se completa con una chaise y un ángulo recto.

Alpino ofrece además otras opciones de personalización al vestir sus formas con todas las colecciones textiles disponibles en nuestro catálogo, y sus esbeltas patas de roble están disponibles en todos los colores de nuestra carta de tintes.

A Natural Connection.

Getting back to nature to recharge and relax is one of the most pleasurable ways to disconnect from everyday routine and stress.

Rafa García is a keen mountain biker and found inspiration for his latest piece, **Alpino**, when he was out and about. The designer has infused the modular sofa with the sense of well-being that he experiences when outdoors, creating a cosy refuge at home.

The soft peaks of the base and back cushions overlap, just like a mountain range. The backrest nestles your head in a comfortable position; ideal for binge-watching, reading or dozing off after a walk in the countryside. A serene and simple design, not without constructive complexity due to its unique arm shapes and the soft yet thin backrests.

Rafa offers multiple solutions to personalise the compositions. An arm with a flap, reminiscent of a draped blanket. Four different types of pouf are available that can be integrated inside the composition as a seat without backrest, create corners, be used as a terminal element or simply as an independent ottoman. A range of modules can be slotted together including a chaise and angle element.

Sancal's extensive textile collection provides the **Alpino** with another layer of personalization and its slender oak legs can be lacquered in a wealth of colours.













11

9

3

10



ALPINO by Rafa García



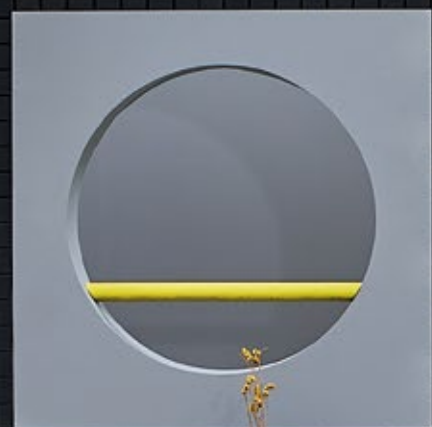

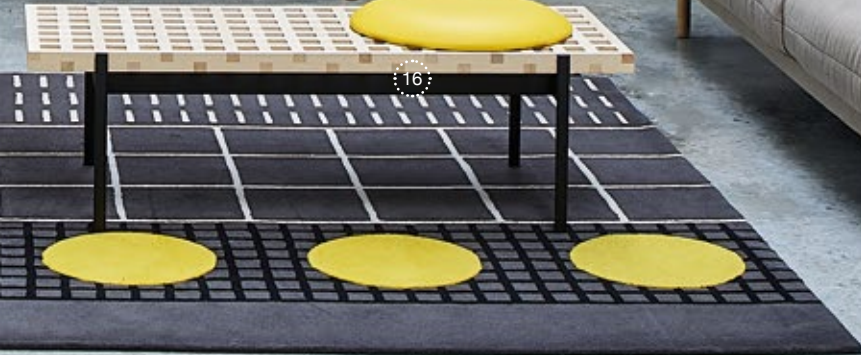







NEXT STOP

By NICHETTO STUDIO

Todo llega para el que sabe esperar.

La hora de salida se aproxima. La larga espera, amenizada por los preparativos para esta etapa del periplo, ha merecido la pena. Iniciado ya el viaje, en breve llegamos al destino elegido. **Next Stop** es la próxima y definitiva parada: un completo programa de asientos desarrollado en colaboración con el diseñador **Luca Nichetto**.

Next Stop forma parte del amplio set de productos que el genio veneciano ha diseñado partiendo de la estación milanesa de **Turati** como inspiración. El lenguaje estético compartido por todo el set armoniza sutilmente su disposición en un mismo ambiente, lo cual no impide recurrir también a su funcionalidad como piezas independientes.

Para su diseño, **Nichetto** toma prestada la racional disposición de los asientos de un vagón y la simetría de las luminarias de la línea M3. Este juego de geometrías da como resultado una amplia familia con múltiples disposiciones.

* El innovador sistema de tapizado aumenta el valor de **Next Stop**, pues está disponible en un tejido de punto exclusivo cuya confección ha sido desarrollada específicamente para este proyecto en colaboración con la diseñadora textil **Marie-Louise Rosholm**. El tejido **Zero** usa la más sofisticada tecnología para confeccionar un traje a medida y generar, como su nombre indica, cero residuos. En cuanto al colorido, **Zero** cambia de dígito y da lugar a cinco combinaciones bi-color, cada una de las cuales exhibe un color puro por cada lado y una mezcla de tonos en todas las intersecciones. De esta forma, el perímetro nos recuerda a un artesanal jersey de punto.

** **Next Stop** también está disponible en una cuidada selección de tejidos estándares.

La modularidad de **Next Stop** se basa en un esquema de plazas de asiento compuesto por tres almohadillas unidas por una funda textil, que sirve de medida para definir sillones, sofás y módulos. Cualquiera de ellos puede incorporar brazos o mesitas auxiliares de diversas medidas. Completan la familia unos bancos de 1 y 2 plazas de asiento que, junto a los módulos hacen posible la creación de infinidad de composiciones. Además, a cualquier pieza se le puede añadir una mesa central, terminal o de ángulo. La estructura metálica que sustenta el conjunto es de acero y está disponible en 2 acabados: epoxi negro texturizado o cromado.

La base del asiento y el respaldo, así como las mesitas están elaboradas en tablero marino chapado en fresno y disponibles en todos sus acabados, o en tablero marino chapado en nogal acabado natural.

Next Stop ha sido concebido para embellecer con singular discreción zonas de espera, espacios de trabajo o áreas multifuncionales y hacer así más agradable el momento de paso. Un diseño con carácter social que enaltece la función de los bancos que se encuentran en las estaciones de metro.

The ability to wait.

All aboard! It's been an exciting build-up, and now it's time to embark on our voyage of discovery. We'll soon be on our way to meet the firm's new soft seating system for the first time. Aptly named **Next Stop**, it has been developed in collaboration with the renowned designer **Luca Nichetto**. **Next Stop** is one of four products designed by the Venetian genius, inspired by the emblematic Milanese station, **Turati** on the M3 line. This provides a common aesthetic that runs through the presentation of

Sancal's diverse collection of new products. Just like people on a station, each of our pieces has its own personality and job to do.

Nichetto took the symmetry of train seats and the M3's lighting as inspiration for the seat and back cushions. The result is an endless modular seating programme.

* **Next Stop** features a revolutionary fabric **Zero**, designed specifically for the product in collaboration with **Marie-Louise Rosholm**. The woollen textile uses the most sophisticated technology to make a tailor-made suit that virtually eliminates seams and waste. There are five bi-colour options to choose from that remind us of a knitted jersey.

** If you would prefer another option, **Next Stop** can also be upholstered in a carefully curated selection of other fabrics.

Next Stop is based on a scheme of cushions made of three seating pads in a textile cover, multiples of which are used to create longer or shorter bench-like seats. Arms can be added to make two and three seaters sofa as well as armchairs. Some configurations leave part of the structure without cushions to reveal a useful table. Two sizes of pouf and additional tables can be attached in the centre, end, or corner. The steel structure is available in a black or chrome, textured epoxy coating.

The table, seat and backrest marine board's veneer is available in ash, which can be stained as per our colour chart, or natural walnut.

This range has been conceived to add a touch of sophistication to lobbies, waiting rooms and breakout areas, reminding us of the function of a humble bench at the metro station.

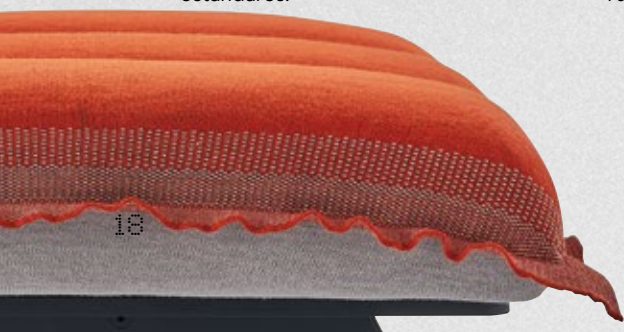

ZERO TEXTILE *

By Marie-Louise Rosholm



ZERO TEXTILE*

By Marie-Louise Rosholm



OTHER FABRICS **



ZERO TEXTILE*

By Marie-Louise Rosholm

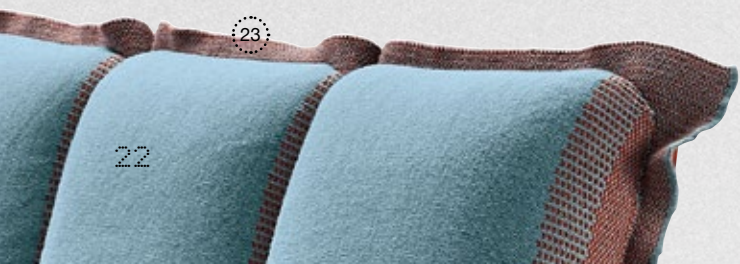
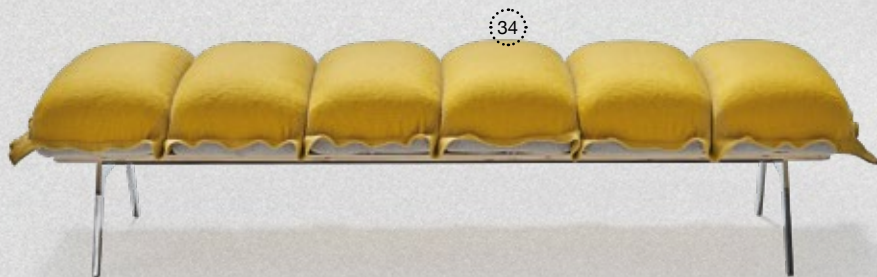

OTHER FABRICS **





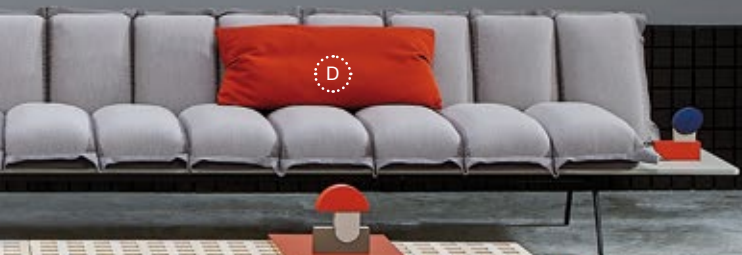

D



22



28

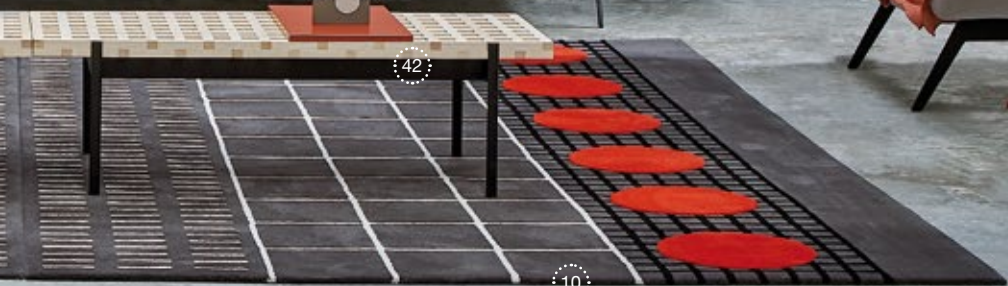

42

10



43

44



44



36



NEXT STOP by Nichetto Studio





NEXT STOP by Nichetto Studio



48



NEXT STOP by Nichetto Studio





49

NEXT STOP by Nichetto Studio







28

22



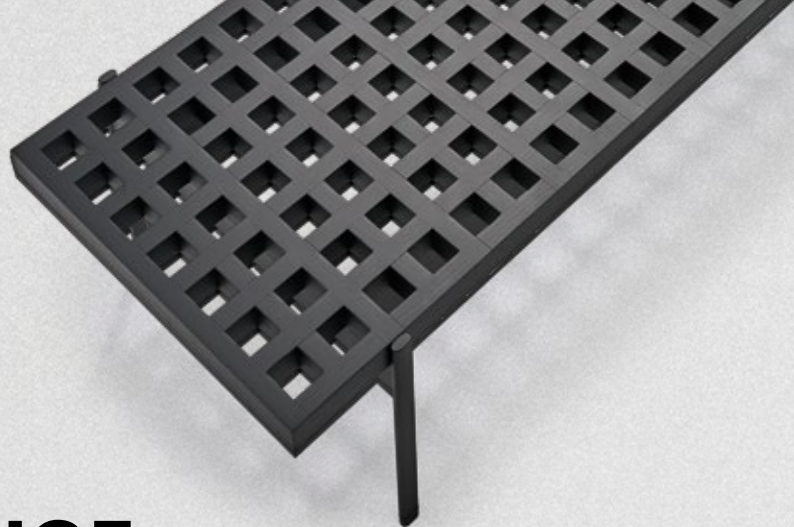

INTERCHANGE

By NICHETTO STUDIO

Cruce de caminos.

Dispersos viajeros se cruzan entre sí con ágiles movimientos, yendo y viniendo en cada trasbordo para acceder a su andén de salida. **Interchange** hace referencia también al más versátil de los cuatro productos del completo set concebido por **Luca Nichetto** para **Sanca**.

La pieza principal de este polivalente modelo es el banco que se inspira en la celosía de la cubierta de la estación **Turati**, un elemento tan arquitectónico como gráfico. Discreto en su forma, pero provocador por las múltiples opciones que se obtienen al combinar variadas geometrías, materiales y usos.

El sobre, elaborado con madera de fresno maciza, dispone de dos medidas y sirve de soporte para realizar extensas configuraciones. Gracias a los huecos de su estructura y a un sencillo sistema de fijación, es posible acoplar diferentes elementos. De este modo, el banco puede incorporar asientos que potencian su confort, mesas de diversas formas y acabados, o paneles que dividen el espacio y crean intimidad.

Las mesas pueden ir ajustadas al perímetro delimitado por el perfil del sobre o volando parcialmente sobre

este. Por el contrario, los asientos tapizados deben colocarse dentro de su perímetro.

La lista de opciones queda completada con los acabados disponibles: 8 colores de tinte para el sobre enrejado, 19 colores de tinte para las mesas de fresno, 4 colores de lacado alto brillo para las mesas de DM, e infinidad de tejidos, vinilos y pieles para los asientos tapizados. Las discretas patas son de acero en acabado epoxi negro texturado y pasan casi inadvertidas en la totalidad de las composiciones.

La versatilidad de **Interchange** queda una vez más manifiesta al poder ser utilizada tanto en espacios domésticos como en proyectos contract.

Crossroads.

Travellers often meet up at junctions to share ideas, **Luca Nichetto's** incredibly versatile **Interchange** helps people do just that.

The bench base is inspired by the architectural forms of **Turati** station's lattice ceiling. A highly adaptable solution, it combines geometry, materials and functions.

The solid ash wood lattice is available in two sizes and serves as a support for a range of configurations. Different elements can be fixed through the holes with a simple fastening system. This way, the bench can incorporate comfortable seats, tables with different shapes and finishes, or dividing panels.

The tables can be fitted to the outer edge of the bench or even poke out slightly. The seats, on the other hand, must always be placed entirely within the perimeter of the lattice.

The personalisation options are completed with eight stain colours for the bench, nineteen stain colours for the ash tables, four high gloss lacquer colours for MDF tables, and endless fabric, vinyl and leather options for the seat cushions.

The discreet legs are made of steel in a textured black epoxy finish.

Interchange's versatility means that it is ideal for both domestic spaces or contract projects.

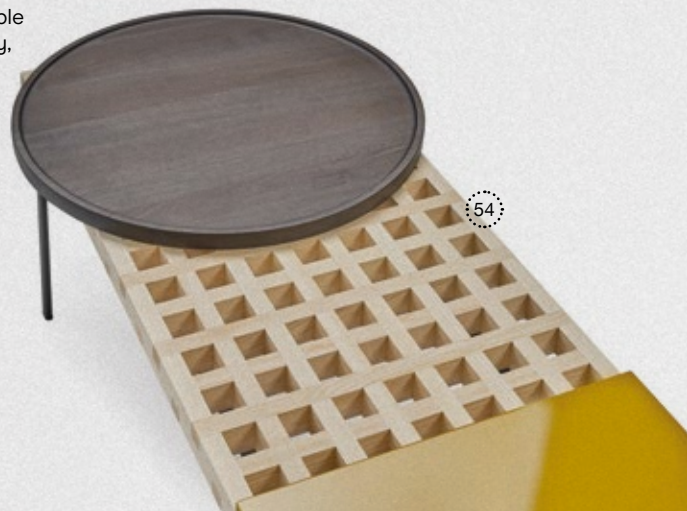

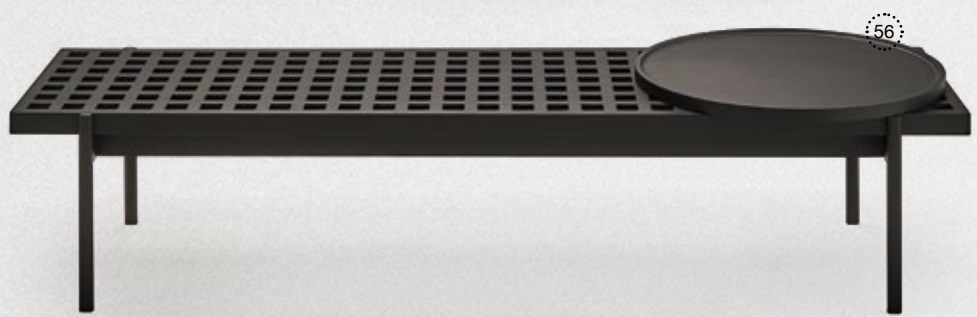
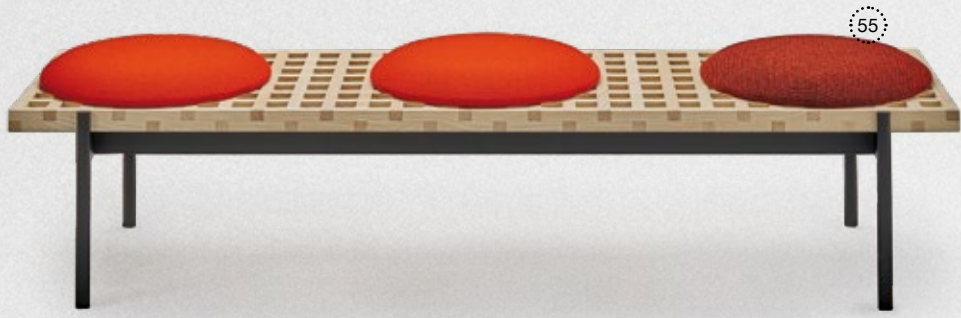

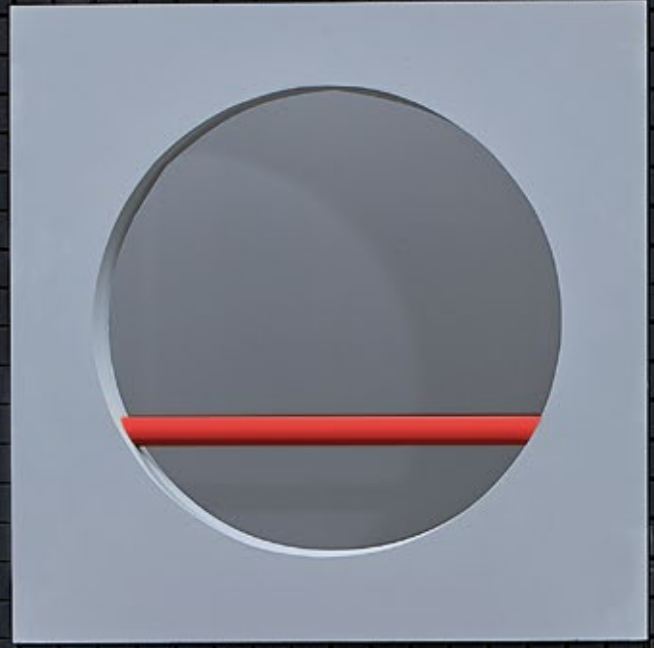

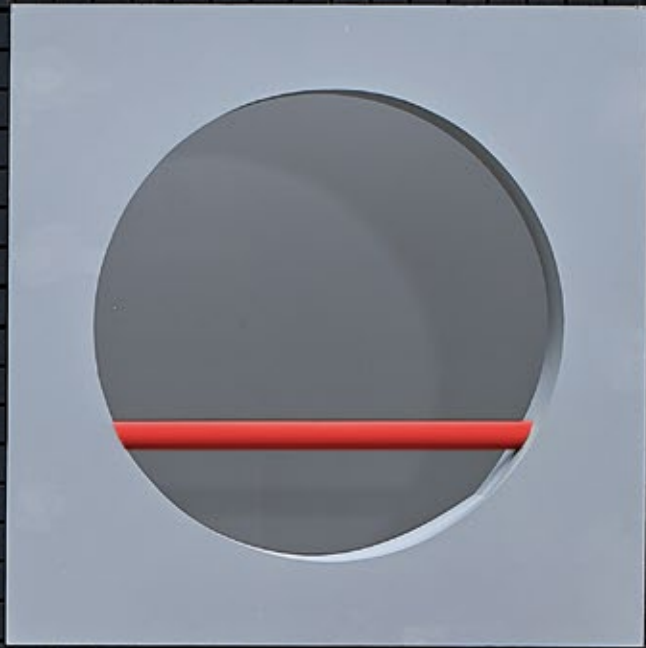

INTERCHANGE by Nichetto Studio



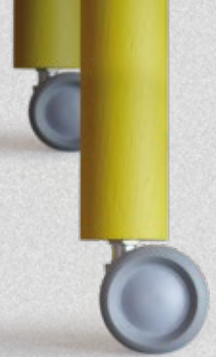

ESTANTE

By JUAN IBÁÑEZ LAX

¡Tela, metal y madera!

Estante es tan versátil y alegre como lo es **Juan Ibáñez Lax**, el polifacético creativo de **Estudio Sancal** y autor de este mueble modular con propiedades fonoabsorbentes.

Los estantes de aluminio son el esqueleto, la pieza central entorno a la cual gira todo. A ellos se añaden las patas y pilastras de roble que los sustentan. Pero sin duda, la máxima distinción viene dada por las piezas textiles que los engalanan.

* Los módulos y puertas tapizadas revisten los estantes e incorporan un diseño fonoabsorbente, trascendiendo así la función decorativa. Las puertas favorecen el contraste de materiales. Las puertas de aluminio han sido perforadas para generar una atractiva textura y no obstaculizar la fonoabsorción.

Estante es tan versátil que amplía el concepto de almacenaje auxiliar. Dependiendo de cómo sea configurado hace las veces de

aparador, recibidor, librería, mueble de tv y hasta de separador de ambientes. La posibilidad de incorporar ruedas incrementa su funcionalidad.

Las patas de roble pueden ser tintadas en toda la carta de colores, lo cual amplía las opciones de personalización.

Estante es un mueble travieso y juguetón, pues en cualquier momento puede cambiar su diseño y sus usos.

Oak, fabric and aluminium play quietly together!

Estante is as versatile and cheerful as **Juan Ibáñez Lax**, **Estudio Sancal's** designer and the author of this modular piece of furniture with acoustic properties.

The aluminium shelves provide the platform upon which everything else is built. Oak pillars and feet screw into place to create the structure which is then adorned by perforated aluminium

or upholstered doors and panels.

* These textile elements dress the **Estante** and add a sound-absorbing function, going beyond mere decoration. The perforated aluminium doors present an attractive contrast while minimising acoustic interference.

The furniture's highly configurable design transcends its storage function as it can be used as sideboard, bookcase, television stand or a divider.

Add wheels to create a trolley or invent your own use case! The oak legs are available in a wide range of colours, providing yet more personalisation.

The **Estante** is so playful that the different elements can be reconfigured at will.



ACOUSTIC FURNITURE *







73

3

ESTANTE by Juan Ibáñez Lax





74

75



MEETING POINT

By NICHETTO STUDIO

Encuentros con desconocidos.

El día previsto, a la hora señalada, los compañeros de viaje se reúnen para iniciar una expedición que se prolongue más allá de la llegada a destino. **Meeting Point** no sólo es lugar en el que se citan pasajeros anónimos y sus privadas historias. Es también es el punto de reunión creado por **Luca Nichetto** para **Sanca**, y su compartido homenaje a la estación **Turati**.

Meeting Point es un sistema de pufs con mesas y representa uno de los cuatro productos independientes y singulares diseñados por el maestro italiano, con una identidad propia muy marcada, pero que, al inspirarse en un mismo lugar, comparte ciertos rasgos que le permiten convivir en mismo set sin estridencias, sutilmente conjuntado.

Las ventanas circulares que se abren a galerías y plataformas son el elemento arquitectónico del que parte el diseño. Así, el círculo es el elemento formal dominante en toda la familia. A los redondeados asientos tapizados de 60 y 90 centímetros de diámetro, le acompañan redondas mesitas de madera o metal de diferentes medidas y acabados.

Las livianas patas son siempre de acero en acabado negro epoxi texturado y crean un efecto óptico de falsa levitación, pues parece que almohada y mesas estén suspendidos en el aire. Las mesas de metal están disponibles en oro y negro texturizado y las de fresno en todos los colores de nuestra carta de tintes. Los asientos se pueden tapizar en una oferta interminable de textiles, vinilos y pieles.

Se puede disponer varios pufs **Meeting Point** para crear una elegante escenografía, tanto en residencias privadas como en las zonas de espera de lobbies u otros espacios corporativos.

Strangers on the station.

On the agreed time and date, travel companions meet each other to set off on an expedition. **Meeting Point** is not only a place where anonymous passengers and their private stories converge. It is also a product created by **Luca Nichetto** for **Sanca**, part of a tribute to the **Turati** station in Milan.

Meeting Point is a pouf system which also integrates tables. It represents one of the four unique products created by the Italian master, each

with its own identity, while sharing a common inspiration and design language.

The circle is the dominant shape, representing the station's hole-like windows that open onto galleries and platforms. Upholstered seats with a diameter of 60 or 90 centimetres are accompanied by round wooden or metal tables of different sizes and finishes.

The thin steel legs, coated in textured black epoxy, create an illusion of levitation, as if the seats and tables are suspended in mid-air. The metal table tops are available in textured black or a gold finish while the ash tables are available in all the colours of Sanca's chart. The seats can be upholstered in an endless array of fabrics, vinyl and leathers.

An arrangement of different **Meeting Points** creates an elegant set in private residences, lobbies, breakout areas or other corporate spaces.





MEETING POINT by Nichetto Studio



39

45

10



78

45

40

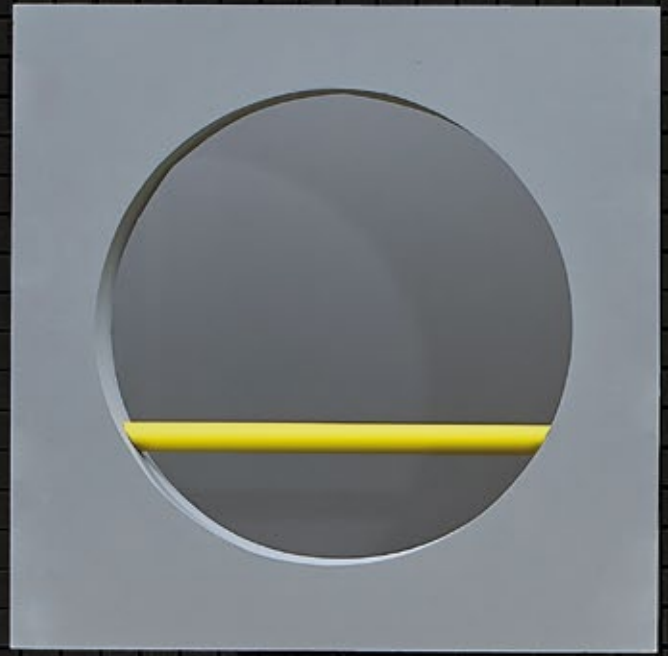



MEETING POINT by Nichetto Studio





13

51



MIND THE GAP

By NICHETTO STUDIO

Empezando con buen pie.

El suave traqueteo de este viaje se interrumpe por los reclamos sonoros de los altavoces al llegar a la parada de **Turati**, advirtiéndonos de esos pequeños huecos entre coche y andén... "Mind the gap" resuena.

Mind the Gap es también un producto de la fructífera colaboración de **Luca Nichetto** con **Sancal**. Y es que esta cálida familia de alfombras arropa al resto de diseños concebidos por el diseñador para amueblar unos sets cuyo común denominador es su principal fuente de inspiración.

Se trata, además, de la primera incursión de la firma en el mundo de las alfombras. **Mind the Gap** cubre un hueco vacío en el catálogo, una categoría de producto en la que la firma tenía ganas de experimentar y completar así su oferta textil.

Para este proyecto **Sancal** ha querido contar con la experiencia y el delicado saber hacer de uno de los telares más antiguos de España. Realizadas en la lana virgen 100% natural por las expertas manos de un selecto equipo de artesanos mediante la técnica hand-tufting, las alfombras **Mind the Gap** se inspiran en los colores y la geometría que encontramos entre

los andenes y galerías de la estación milanesa de **Turati**. El proceso de confección permite crear diseños muy precisos y generar diferentes alturas, lo que potencia los volúmenes del diseño.

Círculos y líneas se entrelazan para crear un patrón muy gráfico, de hipnótica textura. Una única medida de gran formato (200x300) y cinco versiones de color conforman esta mullida familia.

La vocación de esta pieza busca la calidez estética de cualquier espacio y prolongar hasta el infinito el juego de simetrías.

A good way to start.

The soft rattle of a trip on the underground is interrupted by the PA system when arriving at **Turati** station, warning us to be careful about those gaps between the train and the platform ... **Mind the Gap** blares out.

This famous announcement lends its name to one of four new products from the creative collaboration between **Nichetto Studio** and **Sancal**, inspired by Milan's **Turati** station. **Mind the Gap** is a range of warm rugs, a

natural companion to the other three pieces of furniture.

The first incursion of the firm into this product category, **Mind the Gap** fills an empty space in **Sancal's** catalogue, a natural accessory for the brand's upholstery and occasional furniture.

For this project **Sancal** has counted on the experience and the delicate know-how of one of Spain's oldest looms. Made of 100% pure virgin wool by the expert hands of a select team of artisans who use the tufting technique, **Mind the Gap** rugs are inspired by the geometry and colours of **Turati's** platform. The manufacturing process can create very precise designs and generate different heights, adding an extra dimension.

Circles and lines intertwine to create a hypnotic pattern. The rug is available in one size (200x300) with five different colour combinations.

This piece brings warmth to any space and captivates with its seemingly infinite symmetries.

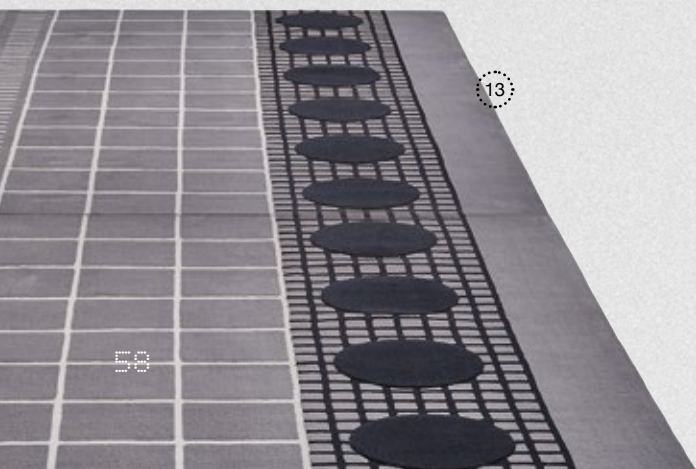

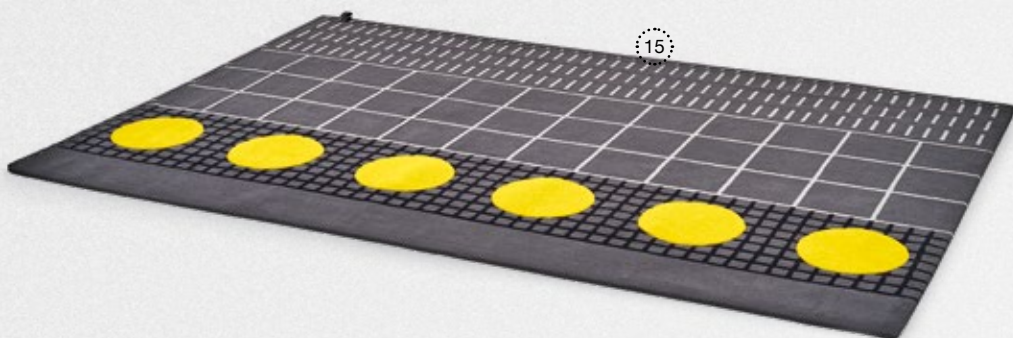
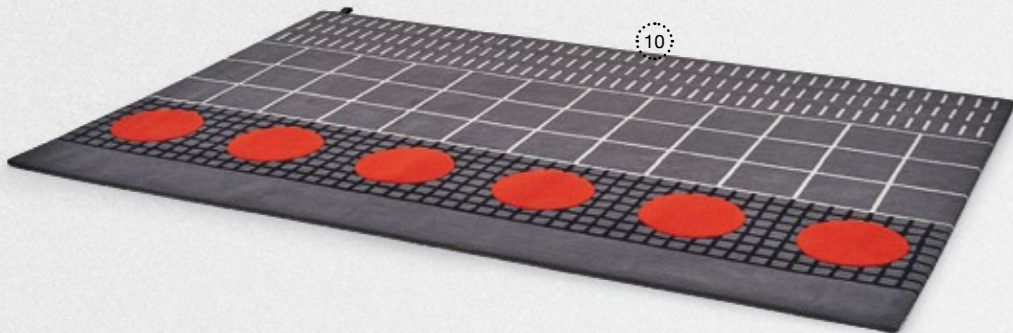
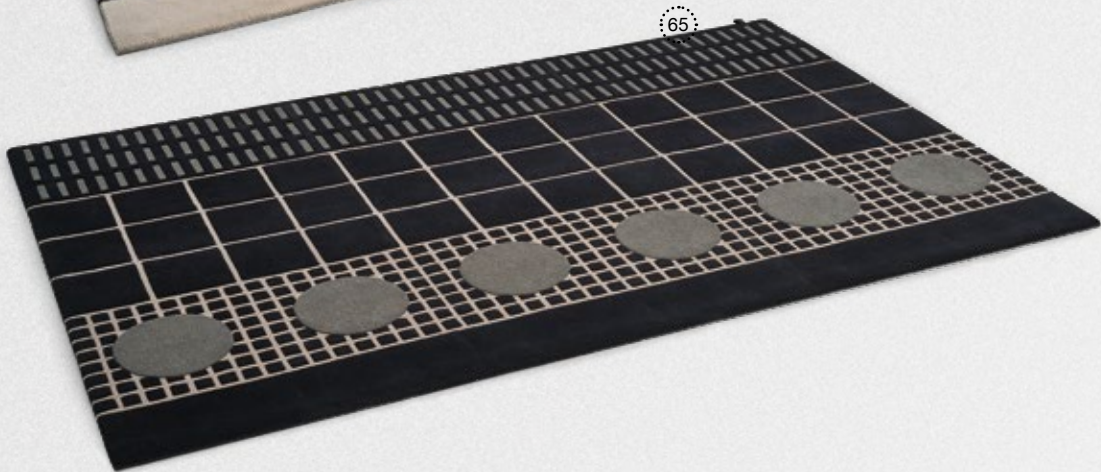
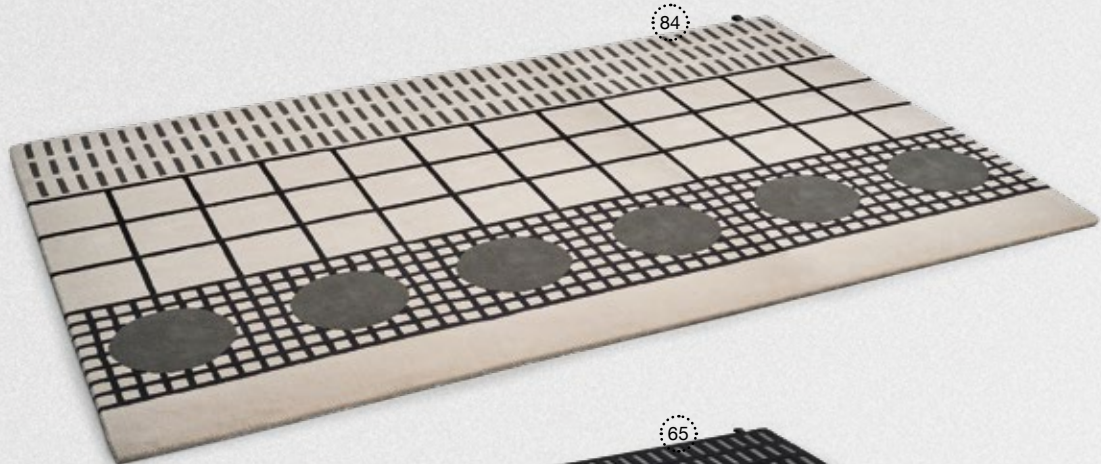

MIND THE GAP by Nichetto Studio







78

65



45

10

84

55



86



TONELLA

By NOTE DESIGN STUDIO

Esos alegres bajitos.

El estudio sueco **Note** nos presenta a los más pequeños de la familia **Tonella**, dos pufs que entran a formar parte de una de las estirpes más distinguidas de **Sancal**.

En esta nueva pieza el asiento adquiere todo el protagonismo por su oronda forma, mientras que las duelas del tonel, elemento inspirador común, tienen una presencia más sutil; aunque igualmente trepan por la base del puf en forma de líneas verticales hasta llegar al asiento, como en el sofá y sillón.

El tapizado del asiento es liso, mientras que el exterior está acolchado. La estructura está disponible en dos acabados metalizados: bronce y nácar.

La nueva generación de **Tonella** se incorpora con energía y dinamismo al catálogo, ofreciendo una pieza fresca y versátil, ideal como plazas de asiento auxiliares en rincones informales o como banqueta para espacios más distinguidos.

Those happy little ones.

The Swedish studio **Note** presents the youngest members of the **Tonella** family, two poufs that join one of **Sancal's** most distinguished sagas.

In this new piece, the chubby upholstered seat is held aloft by a metallic cage support. Wine barrels inspired the original design, the staves of which are represented by the base's vertical bars – a design accent

that runs throughout the family's armchair, sofa and lounge chair.

The seat is plane and contrasts against the outer area's quilting, which follows the lines of the "staves". The metal support is available in two finishes: bronze or nacar.

Tonella's latest addition offers a fresh option, not only as a foot rest, but also a stool in its own right, ideal for any corner or breakout area.



86



47







87

88

TONELLA by Note Design Studio





46

4

90



PION

By IONNA VAUTRIN

Un nuevo tablero para Pion.

La exitosa y elegante **Pion Petra** amplía sus acabados con la incorporación de un granito de fractura irregular en el que predominan los granos negros, grises y blancos, así como de un mármol blanco con pequeñas vetas grises. Esta nueva versión recurre de nuevo a la piedra natural por su innata belleza y sus singulares propiedades de resistencia y durabilidad.

Mientras que los tonos oscuros del granito Ochavo se fusionan con la base en alto brillo de color **Sombra**, la luminosidad del mármol Ibiza queda perfectamente integrado con el acabado **Hielo** de la base.

El uso monocromático del blanco o el negro en esta pieza, inspirada en las figuras de ajedrez, es sencillo y magistral a la vez.

Un nuevo homenaje, quizás el más fiel al juego original, porque en esta ocasión **Ionna** recurre al clásico dúo blanco y negro de las fichas y el tablero como fuente de inspiración.

A new piece for the set.

Black and grey tones mix with white mottling in a new Ochavo granite top, while white Ibiza marble with small grey veins is the other new finish for the successful and elegant **Pion Petra**.

These natural stones convey inherent beauty and they are the strongest and most durable options.

The thin-grain granite's dark tones combine with the table base's high gloss **Sombra** lacquer colour. On the other hand, the marble's brightness matches the **Ice** finish of the base.

Simple and masterful at the same time, the black / white colour selection is a nod to chess, the game that the inspired **Ionna Vautrin** to design the **Pion**.

The base represents a pawn, while the black and white tables top is reminiscent of a chequered chess board.





PION by Ionna Vautrin

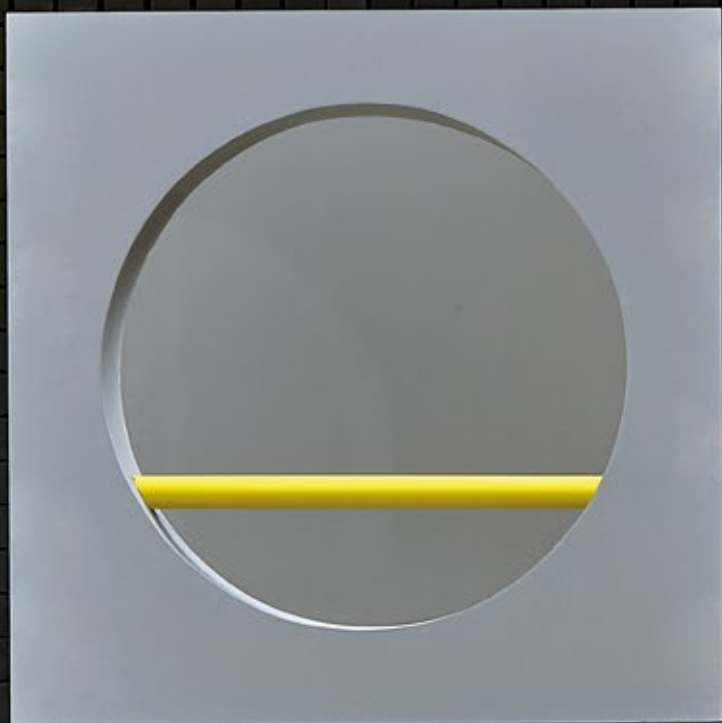



PION by Ionna Vautrin





new OBJETOS / ORNAMENTS

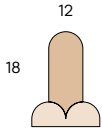

12

18

341.1.CB

ICONS BLOQUES DE MADERA
DECORATIVOS CASUS BELLI
ICONS ORNAMENTAL WOODEN
BLOCKS CASUS BELLI

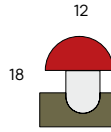

12

18

341.1.FA

ICONS BLOQUES DE MADERA
DECORATIVOS FLY AGARIC
ICONS ORNAMENTAL WOODEN
BLOCKS FLY AGARIC

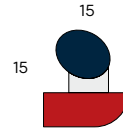

15

15

341.1.CS

ICONS BLOQUES DE MADERA
DECORATIVOS CONTAINER SHIP
ICONS ORNAMENTAL WOODEN
BLOCKS CONTAINER SHIP

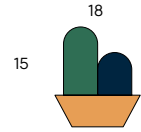

18

15

341.1.M

ICONS BLOQUES DE MADERA
DECORATIVOS MEXICO
ICONS ORNAMENTAL WOODEN
BLOCKS MEXICO

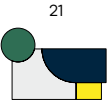

21

12

341.1.D

ICONS BLOQUES DE MADERA
DECORATIVOS DUCK
ICONS ORNAMENTAL WOODEN
BLOCKS DUCK

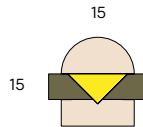

15

15

341.1.D

ICONS BLOQUES DE MADERA
DECORATIVOS CHEESEBURGUER
ICONS ORNAMENTAL WOODEN
BLOCKS CHEESEBURGUER

new PERCHEROS / HOOKS

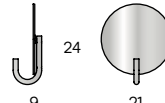

24

9

21

336.38.C.CR

TAIL PERCHERO RADIANTE CROMO D21
TAIL SHINY HOOK CHROME D21

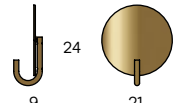

24

9

21

336.38.C.OR

TAIL PERCHERO RADIANTE ORO D21
TAIL SHINY HOOK GOLD D21

JARRONES / VASES



28

27

322.2.S.RC04

FLOWER POWER RAW S CARMIN A04
FLOWER POWER RAW S CARMINE A04



28

27

322.2.S.RP01

FLOWER POWER RAW S PIEDRA A01
FLOWER POWER RAW S STONE A01



28

27

322.2.S.RT02

FLOWER POWER RAW S TOPO A02
FLOWER POWER RAW S TAUPE A02



35

42

322.2.L.RM03

FLOWER POWER RAW L MOSTAZA A03
FLOWER POWER RAW L MUSTARD A03



35

42

322.2.L.RP01

FLOWER POWER RAW L PIEDRA A01
FLOWER POWER RAW L STONE A01



35

42

322.2.L.RT02

FLOWER POWER RAW L TOPO A02
FLOWER POWER RAW L TAUPE A02

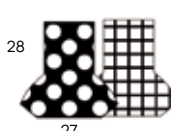

28

27

322.2.S.MO02

FLOWER POWER S MONOCHROME 02
FLOWER POWER S MONOCHROME 02



28

27

322.2.S.WD02

FLOWER POWER S WILD DOTS 02
FLOWER POWER S WILD DOTS 02



28

27

322.2.S.ZZ

FLOWER POWER S VALIENTE 01
FLOWER POWER S VALIENTE 01



28

27

322.2.S.GR01

FLOWER POWER S GRID 01
FLOWER POWER S GRID 01



35

42

322.2.L.BG02

FLOWER POWER L BANANA GUYS 02
FLOWER POWER L BANANA GUYS 02



35

42

322.2.L.MO01

FLOWER POWER L MONOCHROME 01
FLOWER POWER L MONOCHROME 01



35

42

322.2.LUJ02

FLOWER POWER L URBAN JUNGLE 02
FLOWER POWER L URBAN JUNGLE 02



35

42

322.2.L.RE01

FLOWER POWER L RELAX 01
FLOWER POWER L RELAX 01

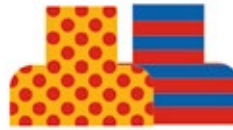

35

42

322.2.L.RU01

FLOWER POWER L RUMBA 01
FLOWER POWER L RUMBA 01Z

new CESTOS / SACKS



20

29

340.3PN.S.GY

FLOPPY CESTO S GREY BRICKS
FLOPPY SACK S GREY BRICKS



20

29

340.3PN.S.LM

FLOPPY CESTO S LIMA BRICKS
FLOPPY SACK S LIME BRICKS



20

29

340.3PN.S.PH

FLOPPY CESTO S PEACH BRICKS
FLOPPY SACK S PEACH BRICKS



65

64

340.3PN.XL.GY

FLOPPY CESTO XL GREY BRICKS
FLOPPY SACK XL GREY BRICKS



65

64

340.3PN.XL.WH

FLOPPY CESTO XL WHITE BRICKS
FLOPPY SACK XL WHITE BRICKS

COJINES / CUSHIONS



30

30

324.22.DD.C1

RIFT COJIN 30X30 VERDE
RIFT CUSHION 30X30 GREEN



30

30

324.22.DD.C2

RIFT COJIN 30X30 TEJA
RIFT CUSHION 30X30 BRICK-RED



30

30

324.22.DD.C3

RIFT COJIN 30X30 AMARILLO
RIFT CUSHION 30X30 YELLOW



30

30

324.22.DD.C4

RIFT COJIN 30X30 AZUL
RIFT CUSHION 30X30 BLUE



40

40

324.22.EE.C1

RIFT COJIN 40X40 VERDE
RIFT CUSHION 40X40 GREEN



40

40

324.22.EE.C2

RIFT COJIN 40X40 TEJA
RIFT CUSHION 40X40 BRICK-RED

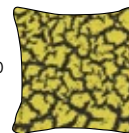

40

40

324.22.EE.C3

RIFT COJIN 40X40 AMARILLO
RIFT CUSHION 40X40 YELLOW



40

40

324.22.EE.C4

RIFT COJIN 40X40 AZUL
RIFT CUSHION 40X40 BLUE



66

66

324.22.GG.C1X

RIFT COJIN FINO 66X66 VERDE
RIFT FLOPPY CUSHION 66X66 GREEN



66

66

324.22.GG.C2X

RIFT COJIN FINO 66X66 TEJA
RIFT FLOPPY CUSHION
66X66 BRICK-RED

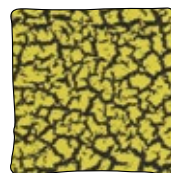

66

66

324.22.GG.C3X

RIFT COJIN FINO 66X66 AMARILLO
RIFT FLOPPY CUSHION
66X66 YELLOW



66

66

324.22.GG.C4X

RIFT COJIN FINO 66X66 AZUL
RIFT FLOPPY CUSHION 66X66 BLUE

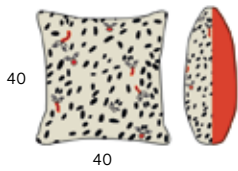

323.22.EE.WD01

FLORA & FAUNA COJIN 40X40
WILD DOTS 01 / PELO NARANJA
FLORA & FAUNA CUSHION
40X40 - WD01 / ORANGE FUR



323.22.EE.BG01

FLORA & FAUNA COJIN 40X40
BANANA GUYS 01 / PELO AZUL
FLORA & FAUNA CUSHION
40X40 - BG01 / BLUE FUR

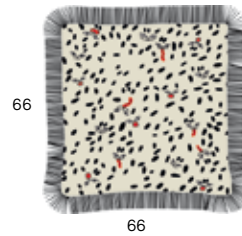

323.22.GG.WD01

FLORA & FAUNA COJIN 66X66
C/ FLECOS - WILD DOTS 01
FLORA & FAUNA CUSHION
66X66 W/FRINGES - WD01



323.22.GG.BG01

FLORA & FAUNA COJIN 66X66
C/ FLECOS - BANANA GUYS 01
FLORA & FAUNA CUSHION
66X66 W/FRINGES - BG01

MANTAS / BLANKETS

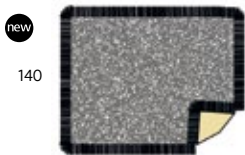

321.3M.L.MFN

TÁPAME MUCHO L MONOCHROME
TÁPAME MUCHO L MONOCHROME

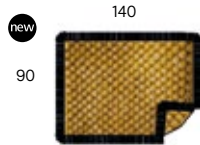

321.3M.S.BPA

TÁPAME MUCHO S BUMPY AMARILLO
TÁPAME MUCHO S BUMPY YELLOW

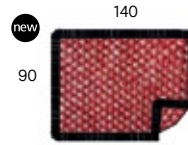

321.3M.S.BPR

TÁPAME MUCHO S BUMPY ROJO
TÁPAME MUCHO S BUMPY RED

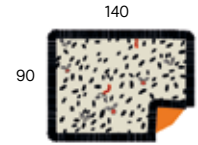

321.3M.S.WD01

TÁPAME MUCHO S WILD DOTS BEIGE
FLECO NEGRO
TÁPAME MUCHO S BEIGE WILD DOTS
BLACK FRINGES

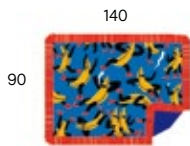

321.3M.S.BG01

TÁPAME MUCHO S BANANA GUYS
AZUL FLECO ROJO
TÁPAME MUCHO S BLUE BANANA
GUYS RED FRINGES

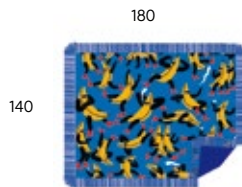

321.3M.L.BG01

TÁPAME MUCHO L BANANA GUYS
AZUL FLECO AZUL
TÁPAME MUCHO L BLUE BANANA
GUYS BLUE FRINGES

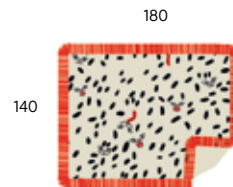

321.3M.L.WD01

TÁPAME MUCHO L WILD DOTS BEIGE
FLECO ROJO
TÁPAME MUCHO L BEIGE WILD DOTS
RED FRINGES

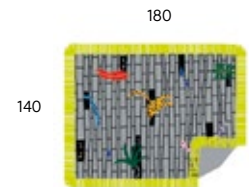

321.3M.L.UJ01

TÁPAME MUCHO L URBAN JUNGLE GRIS
FLECO AMARILLO
TÁPAME MUCHO L GREY URBAN JUNGLE
YELLOW FRINGES

new PAPELERÍA / STATIONERY



326.3M.MM

BORN FREE MINI MANTA ACOLCHADA
119X116
BORN FREE TINY QUILTED THROW
119X116

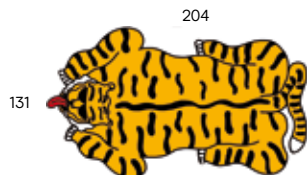

325.3M.PW

LINDO GATITO MANTA
ACOLCHADA 131X204
LINDO GATITO QUILTED THROW
131X204



337.A5.WDN

NOTES WILD DOTS A5 LIBRETA
NOTES WILD DOTS A5 NOTEBOOK



337.A5.RFN

NOTES RIFT A5 LIBRETA
NOTES RIFT A5 NOTEBOOK



337.A6.HVN

NOTES FROM HEAVEN
PACK 2 A6 LIBRETAS
NOTES FROM HEAVEN
PACK 2 A6 NOTEBOOKS



337.A6.HLL

NOTES FROM HELL
PACK 2 A6 LIBRETAS
NOTES FROM HELL
PACK 2 A6 NOTEBOOKS

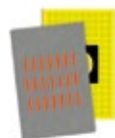

337.A6.TRT

NOTES FROM TURATI
PACK 2 A6 LIBRETAS
NOTES FROM TURATI
PACK 2 A6 NOTEBOOKS



337.A6.SYH

NOTES FROM SEA & HILL
PACK 2 A6 LIBRETAS
NOTES FROM SEA & HILL
PACK 2 A6 NOTEBOOKS



339.00.GD

GEOMETRIC DOODLES
PACK 3 LÁPICES

new FUNDAS TABLETS & PORTÁTILES / TABLETS & LAPTOP COVERS

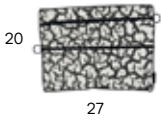

324.3D.S.C5
RIFT FUNDA PROTECTORA S BLANCA
RIFT COVER S WHITE

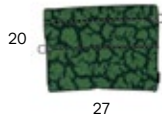

324.3D.S.C1
RIFT FUNDA PROTECTORA S VERDE
RIFT COVER S GREEN

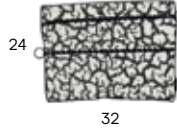

324.3D.M.C5
RIFT FUNDA PROTECTORA M BLANCA
RIFT COVER M WHITE

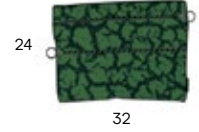

324.3D.M.C1
RIFT FUNDA PROTECTORA M VERDE
RIFT COVER M GREEN

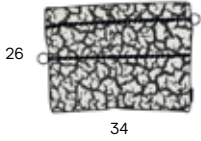

324.3D.L.C5
RIFT FUNDA PROTECTORA L BLANCA
RIFT COVER L WHITE



324.3D.L.C1
RIFT FUNDA PROTECTORA L VERDE
RIFT COVER L GREEN

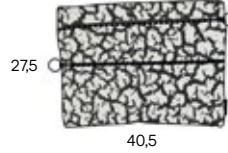

324.3D.XL.C5
RIFT FUNDA PROTECTORA XL BLANCA
RIFT COVER XL WHITE

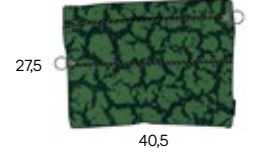

324.3D.XL.C1
RIFT FUNDA PROTECTORA XL VERDE
RIFT COVER XL GREEN

BOLSOS / BAGS



338.3MO.CCL
MOCHILA LBB CICLO
BACKPACK LBB CYCLE



338.3MO.CML
MOCHILA LBB CAMEL
BACKPACK LBB CAMEL



338.3MO.ONX
MOCHILA LBB ONIX
BACKPACK LBB ONIX



342.MO2.S.BN
SHOPPING BAG S BANANA
SHOPPING BAG S BANANA



327.3MO.APG01
SIN PISTOLS MOCHILA CENIZA
SIN PISTOLS ASH BACKPACK



327.3MO.APG02
SIN PISTOLS MOCHILA MARINO
SIN PISTOLS NAVY BACKPACK



327.3MO.APG03
SIN PISTOLS MOCHILA JEANS
SIN PISTOLS JEANS BACKPACK



327.3MO.APM01
SIN PISTOLS MOCHILA TEJA
SIN PISTOLS BRICK BACKPACK



327.3MO.ATN01
SIN PISTOLS MOCHILA CARBON
SIN PISTOLS CARBON BACKPACK



327.3MO.ATN02
SIN PISTOLS MOCHILA TOPO
SIN PISTOLS TAUPE BACKPACK



327.3MO.ATN03
SIN PISTOLS MOCHILA NIEVE
SIN PISTOLS SNOW BACKPACK



327.3MO.ATN04
SIN PISTOLS MOCHILA LIMON
SIN PISTOLS LEMON BACKPACK

**ÍNDICE
TÉCNICO**

**TECHNICAL
INDEX**

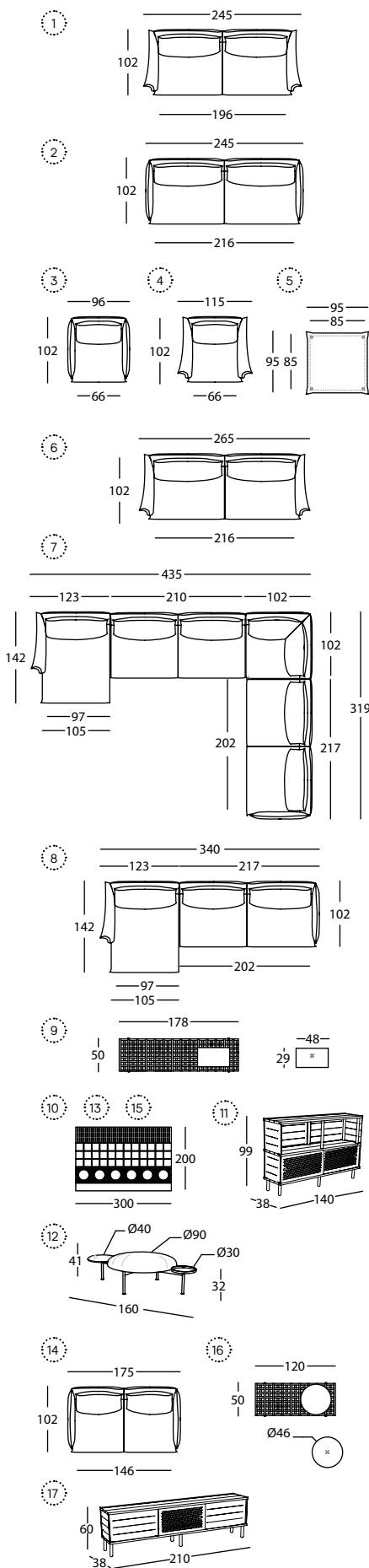

ID	UNL. QTY.	MOD.	REF.	DESCRIPCIÓN / DESCRIPTION	ACABADO FINISHES	TELAS MATERIAL	SERIES	MUESTRARIO SAMPLE BK.
1	1	ALPINO	331.11.V.BS	SOFA 245 BR SOLAPA SOFA 245 ARM W/FLAP	108-NEGRO BLACK	6115	6	115
2	1	ALPINO	331.11.X.5	SOFA 245 BR RECTO SOFA 245 PLAIN ARM	002-NATURAL	2853	2	125
3	1	ALPINO	331.11.G.5	SILLON 95 BR RECTO ARMCHAIR 115 PLAIN ARM	043-MANGO	SOFT 05011	12P	ELMO SOFT
4	1	ALPINO	331.11.G.BS	SILLON 115 BR SOLAPA ARMCHAIR 115 ARM W/FLAP	108-NEGRO BLACK	6170	6	119
5	1	ALPINO	331.15.J	PUF 95X95 POUF 95X95	042-AMARILLO YELLOW	STEP 62057	3	108 (STEP)
6	1	ALPINO	331.11.X.BS	SOFA 265 BR SOLAPA SOFA 265 ARM W/FLAP	002-NATURAL	5000	5	122
7	1	ALPINO	331.14.L.BS.I	CHAISE 123X142 BR SOLAPA IZDO CHAISE LONGUE 123X142 LEFT ARM W/FLAP	043-MANGO	7215	7	127
7	1	ALPINO	331.12.V	MODULO 210 MODULE 210	043-MANGO	7215	7	127
7	1	ALPINO	331.161.L	ANGULO RECTO 102X102 CORNER 102X102	043-MANGO	7215	7	127
7	1	ALPINO	331.12.V.5.D	MOD 217 BR RECTO DCHO MOD 217 RIGHT PLAIN ARM	043-MANGO	7215	7	127
8	1	ALPINO	331.14.L.BS.I	CHAISE 123X142 BR SOLAPA IZDO CHAISE LONGUE 123X142 LEFT ARM W/FLAP	043-MANGO	7215	7	127
8	1	ALPINO	331.12.V.5.D	MOD 217 BR RECTO DCHO MOD 217 RIGHT PLAIN ARM	043-MANGO	7215	7	127
9	1	INTERCHANGE	332.88.N	BANCO 120X50 BENCH 120x50	003-NOGAL WALNUT	-	-	-
9	1	INTERCHANGE	332.3Q.C	MESITA DM BRILLO 29X48 GLOSSY MDF TABLE 29X48	129-OXIDO RUST RED	-	-	-
10	2	MIND THE GAP	334.6.WZ7.R	ALFOMBRA 200X300 PUNTO ROJO CARPET 200X300 RED DOTS	-	-	-	-
11	1	ESTANTE	335.84.QK	ESTRUCTURA 140X99 STRUCTURE 140X99	049-GRIS SEDA SILK GREY	-	-	-
11	2	ESTANTE	335.8A.Q.LA	140 TRASERAS Y LATERALES TEXTILES 140 UPHOL. BACK & SIDE PANELS	-	UNIFORM MEL SMOKE	8	KVADRAT FEBRIK
11	1	ESTANTE	335.8A.Q.AL	140 - 2 PUERTAS DE ALUMINIO 140 - 2 ALUMINIUM DOORS	-	-	-	-
12	1	MEETING POINT	333.15.S.7	PUF 160x90 MESA D30 METAL POUF 160x90 TABLE D30 METAL	049-GRIS SEDA SILK GREY / 155-ORO GOLD	PLECTO 0244	9	KVADRAT FEBRIK
13	1	MIND THE GAP	334.6.WZ7.S	ALFOMBRA 200X300 PIEDRA CARPET 200X300 STONE	-	-	-	-
14	1	ALPINO	331.11.S.5	SOFA 175 BR RECTO SOFA 175 PLAIN ARM	003-NOGAL WALNUT	3847	2	83
15	1	MIND THE GAP	334.6.WZ7.Y	ALFOMBRA 200X300 PUNTO AMARILLO CARPET 200X300 YELLOW DOTS	-	-	-	-
16	1	INTERCHANGE	332.88.N	BANCO 120X50 BENCH 120x50	002-NATURAL	-	-	-
16	1	INTERCHANGE	332.3R.E	ASIENTO D46 SEAT D46	-	SOFT 44026	12P	ELMO SOFT
17	1	ESTANTE	335.84.XG	ESTRUCTURA 210X60 STRUCTURE 210X60	002-NATURAL	-	-	-
17	1	ESTANTE	335.8A.X.LA	210 TRASERAS Y LATERALES TEXTILES 210 UPHOL. BACK & SIDE PANELS	-	UNIFORM MEL BANANA	8	KVADRAT FEBRIK
17	1	ESTANTE	335.8A.X.MXTA	210 - 2 PUERTAS TEXTIL Y 1 PUERTA ALUMINIO 210 - 2 UPHOLSTERED & 1 ALUMINIUM DOORS	-	UNIFORM MEL BANANA	8	KVADRAT FEBRIK

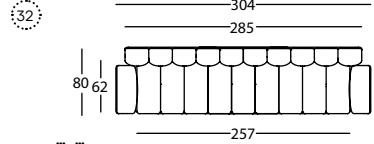
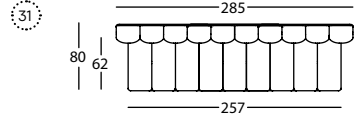
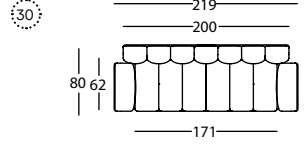
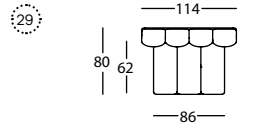
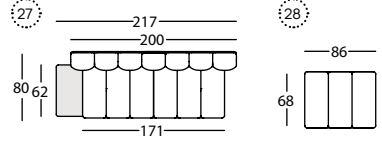
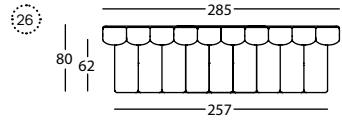
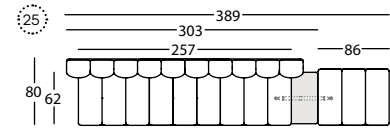
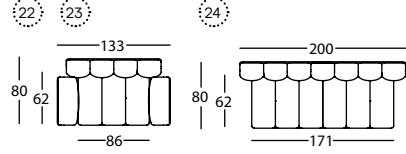
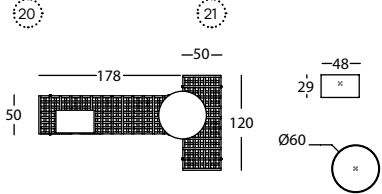
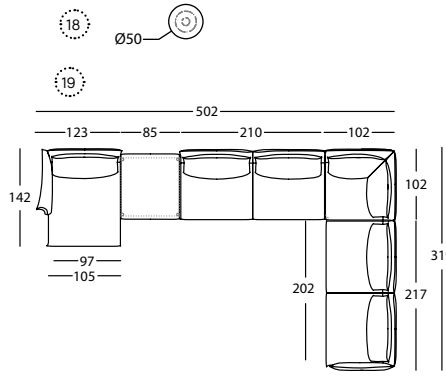

ID	UNI. QTY.	MOD.	REF.	DESCRIPCIÓN / DESCRIPTION	ACABADO FINISHES	TELAS MATERIAL	SERIES	MUESTRARIO SAMPLE BK.
18	1	PION PETRA	284.71.FE.A6	MESITA D50X40 TABLE D50X40	SOMBRA / OCHAVO SHADOW / OCHAVO	-	-	-
19	1	ALPINO	331.14.L.BS.I	CHAISE 123X142 BR SOLAPA IZDO CHAISE LONGUE 123X142 LEFT ARM W/FLAP	049-GRIS SEDA SILK GREY	7215	7	127
19	1	ALPINO	331.15.J.CT	PUF CENTRAL 85X95 CENTRAL POUF 85X95	049-GRIS SEDA SILK GREY	7215	7	127
19	1	ALPINO	331.12.V	MODULO 210 MODULE 210	049-GRIS SEDA SILK GREY	7215	7	127
19	1	ALPINO	331.161.L	ANGULO RECTO 102X102 CORNER 102X102	049-GRIS SEDA SILK GREY	7215	7	127
19	1	ALPINO	331.12.V.5.D	MOD 217 BR RECTO DCHO MOD 217 RIGHT PLAIN ARM	049-GRIS SEDA SILK GREY	7215	7	127
20	1	INTERCHANGE	332.88.T	BANCO 178X50 BENCH 178x50	108-NEGRO BLACK	-	-	-
20	1	INTERCHANGE	332.3Q.C	MESITA DM BRILLO 29X48 GLOSSY MDF TABLE 29X48	116-MOSTAZA MUSTARD	-	-	-
20	1	INTERCHANGE	332.32.G	MESITA FRESNO D60 ASH WOOD TABLE D60	108-NEGRO BLACK	-	-	-
21	1	INTERCHANGE	332.88.N	BANCO 120X50 BENCH 120x50	002-NATURAL	-	-	-
22	1	NEXT STOP	328.11.M	SILLON 133 ARMCHAIR 133	108-NEGRO BLACK / 151-NEGRO BLACK	ZERO RUST RED	11	ZERO
23	1	NEXT STOP	328.11.M	SILLON 133 ARMCHAIR 134	108-NEGRO BLACK / 151-NEGRO BLACK	ZERO PETROL	11	ZERO
24	1	NEXT STOP	328.12.X	MODULO 200 NOGAL MODULE 200 WALNUT	002-NATURAL / 084-CROMO CHROME	ZERO YELLOW	11	ZERO
25	1	NEXT STOP	328.12.Z7.D	MOD 285 C/MESA DCHO MOD 285 W/RIGHT TABLE	049-GRIS SEDA SILK GREY / 155-NEGRO BLACK	ZERO LIGHT GREY	11	ZERO
25	1	NEXT STOP	328.31.F	PIEZA UNIMODULOS LINKING PIECE	155- NEGRO BLACK	-	-	-
25	1	NEXT STOP	328.10.J	BANCO 86 BENCH 86	049-GRIS SEDA SILK GREY / 155- NEGRO BLACK	ZERO MAUVE	11	ZERO
26	1	NEXT STOP	328.12.Z7	MODULO 285 MODULE 285	049-GRIS SEDA SILK GREY / 155- NEGRO BLACK	ZERO LIGHT GREY	11	ZERO
27	1	NEXT STOP	328.12.X.I	MOD 200 C/MESA IZDO MOD 200 W/LEFT TABLE	006-ANTRACITA ANTHRACITE / 151-NEGRO BLACK	ZERO MAUVE	11	ZERO
28	1	NEXT STOP	328.10.J	BANCO 86 BENCH 86	108-NEGRO BLACK / 151-NEGRO BLACK	ZERO RUST RED	11	ZERO
29	1	NEXT STOP	328.12.P	MODULO 114 MODULE 114	107-BLANCO WHITE / 151-NEGRO BLACK	6172	6	119
30	1	NEXT STOP	328.11.W	SOFA 219 NOGAL SOFA 219 WALNUT	002-NATURAL / 084-CROMO	6251	6	126
31	1	NEXT STOP	328.12.Z7	MODULO 285 MODULE 285	108-NEGRO BLACK / 151-NEGRO BLACK	ATLANTIC 67043	2	112 (ATLANTIC)
32	1	NEXT STOP	328.11.Z5	SOFA 304 FRESNO SOFA 304 ASH	002 NATURAL / 151-NEGRO BLACK	ATLANTIC 64092	2	112 (ATLANTIC)

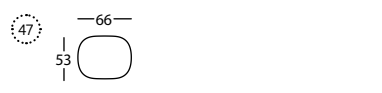
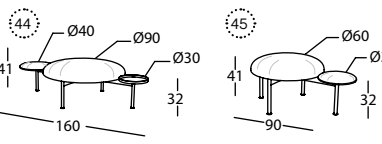
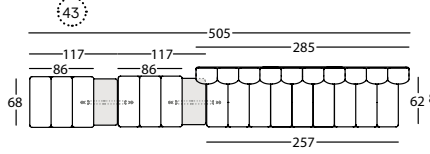
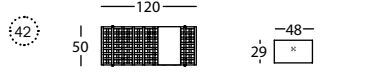
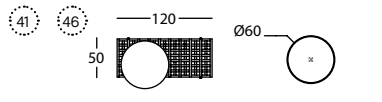
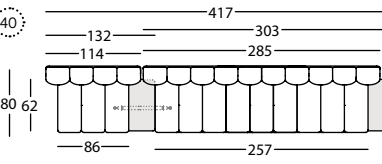
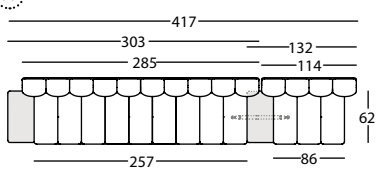
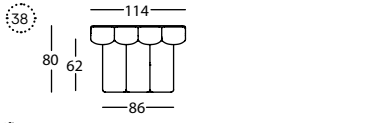
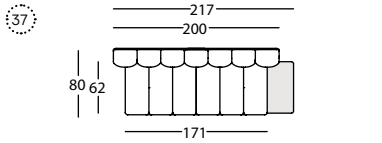
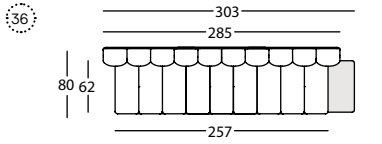
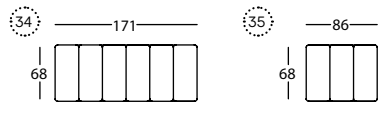
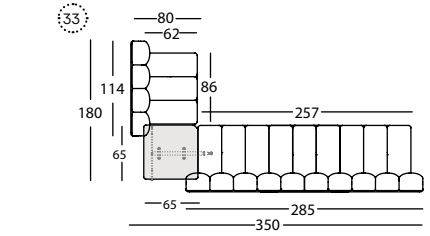

ID	UNI. QTY.	MOD.	REF.	DESCRIPCIÓN / DESCRIPTION	ACABADO FINISHES	TELAS MATERIAL	SERIES	MUESTRARIO SAMPLE BK.
33	1	NEXT STOP	328.12.Z7	MODULO 285 NOGAL MODULE 285 WALNUT	002-NATURAL / 084-CROMO CHROME	ZERO YELLOW	11	ZERO
33	1	NEXT STOP	328.77.C.D	MESA ANGULO DCHO NOGAL RIGHT CORNER TABLE WALNUT	002-NATURAL / 084-CROMO CHROME	-	-	-
33	1	NEXT STOP	328.12.P	MODULO 114 NOGAL MODULE 114 WALNUT	002-NATURAL / 084-CROMO CHROME	ZERO YELLOW	11	ZERO
34	1	NEXT STOP	328.10.T	BANCO 171 NOGAL BENCH 171 WALNUT	002-NATURAL / 084-CROMO CHROME	ZERO YELLOW	11	ZERO
35	1	NEXT STOP	328.10.J	BANCO 86 NOGAL BENCH 86 WALNUT	002-NATURAL / 084-CROMO CHROME	ZERO MAUVE	11	ZERO
36	1	NEXT STOP	328.12.Z7.D	MOD 285 C/MESA DCHO MOD 285 W/RIGHT TABLE	049-GRIS SEDA SILK GREY / 155-NEGRO BLACK	ZERO LIGHT GREY	11	ZERO
37	1	NEXT STOP	328.12.X.D	MOD 200 C/MESA DCHO MOD 200 W/RIGHT TABLE	108-NEGRO BLACK / 151-NEGRO BLACK	6216	6	121
38	1	NEXT STOP	328.12.P	MODULO 114 MODULE 114	056-ROJO RED / 151-NEGRO BLACK	7203	7	124 (RIFT)
39	1	NEXT STOP	328.12.Z7.I	MOD 285 C/MESA IZDO MOD 285 W/LEFT TABLE	049-GRIS SEDA SILK GREY / 155-NEGRO BLACK	ZERO LIGHT GREY	11	ZERO
39	1	NEXT STOP	328.31.F	PIEZA UNIMODULOS LINKING PIECE	155- NEGRO BLACK	-	-	-
39	1	NEXT STOP	328.12.P.I	MOD 114 C/MESA IZDO MOD 114 W/LEFT TABLE	049-GRIS SEDA SILK GREY / 155- NEGRO BLACK	ZERO RUSTED RED	11	ZERO
40	1	NEXT STOP	328.12.P.D	MOD 114 C/MESA DCHO MOD 114 W/RIGHT TABLE	049-GRIS SEDA SILK GREY / 155- NEGRO BLACK	ZERO RUSTED RED	11	ZERO
40	1	NEXT STOP	328.31.F	PIEZA UNIMODULOS LINKING PIECE	155- NEGRO BLACK	-	-	-
40	1	NEXT STOP	328.12.Z7.D	MOD 285 C/MESA DCHO MOD 285 W/RIGHT TABLE	049-GRIS SEDA SILK GREY / 155- NEGRO BLACK	ZERO LIGHT GREY	11	ZERO
41	1	INTERCHANGE	332.88.N	BANCO 120X50 BENCH 120x50	002-NATURAL	-	-	-
41	1	INTERCHANGE	332.32.G	MESITA FRESNO D60 ASH WOOD TABLE D60	055- SOMBRA SHADOW	-	-	-
42	1	INTERCHANGE	332.88.N	BANCO 120X50 BENCH 120x50	002-NATURAL	-	-	-
42	1	INTERCHANGE	332.3Q.C	MESITA DM BRILLO 29X48 GLOSSY MDF TABLE 29X48	129-OXIDO RUST RED	-	-	-
43	2	NEXT STOP	328.10.M.I	BANCO 86 C/MESA DCHO BENCH 86 W/RIGHT TABLE	049-GRIS SEDA SILK GREY / 155- NEGRO BLACK	ZERO LIGHT GREY	11	ZERO
43	2	NEXT STOP	328.31.F	PIEZA UNIMODULOS LINKING PIECE	155- NEGRO BLACK	-	-	-
43	1	NEXT STOP	328.12.Z7.D	MOD 285 MOD 285	049-GRIS SEDA SILK GREY / 155- NEGRO BLACK	ZERO LIGHT GREY	11	ZERO
44	1	MEETING POINT	333.15.S.7	PUF 160x90 MESA D30 METAL POUF 160x90 TABLE D30 METAL	108-NEGRO BLACK / 151-NEGRO BLACK	ATLANTIC 62049	2	112 (ATLANTIC)
45	1	MEETING POINT	333.15.KG	PUF 90x60 MESA D30 FRESNO POUF 90x60 TABLE D30 ASH	108-NEGRO BLACK	6252	6	126
46	1	INTERCHANGE	332.88.N	BANCO 120X50 BENCH 120x50	003-NOGAL WALNUT	-	-	-
46	1	INTERCHANGE	332.32.G	MESITA FRESNO D60 ASH WOOD TABLE D60	043-MANGO	-	-	-
47	1	TONELLA	301.15.GF	PUF 66X53 POUF 66X53	103-NACAR	7212	7	127

ID	UNL. QTY.	MOD.	REF.	DESCRIPCIÓN / DESCRIPTION	ACABADO FINISHES	TELAS MATERIAL	SERIES	MUESTRARIO SAMPLE BK.
48	2	NEXT STOP	328.10.J	BANCO 86 BENCH 86	108-NEGRO BLACK / 151-NEGRO BLACK	ZERO RUST RED	11	ZERO
48	3	NEXT STOP	328.71.A	MESA UNION INTERCONNECTING TABLE	108-NEGRO BLACK / 151-NEGRO BLACK	-	-	-
48	2	NEXT STOP	328.12.P	MODULO 114 MODULE 114	108-NEGRO BLACK / 151-NEGRO BLACK	ZERO RUST RED	11	ZERO
48	1	NEXT STOP	328.2H.MIX	KIT ELÉCTRICO MIXTO 1 BASE ENCHUFE + 1 USB MIXED ELECTRIC SET 1 PLUG BASE + 1 USB	-	-	-	-
49	1	NEXT STOP	328.12.X.I	MOD 200 C/MESA IZDO MOD 200 W/LEFT TABLE	049-GRIS SEDA SILK GREY / 155- NEGRO BLACK	ZERO MAUVE	11	ZERO
49	1	NEXT STOP	328.77.C.D	MESA ANGULO DCHO RIGHT CORNER TABLE	049-GRIS SEDA SILK GREY / 155- NEGRO BLACK	ZERO MAUVE	11	ZERO
49	1	NEXT STOP	328.10.J	BANCO 86 BENCH 86	049-GRIS SEDA SILK GREY / 155- NEGRO BLACK	ZERO MAUVE	11	ZERO
49	1	NEXT STOP	328.71.A	MESA UNION INTERCONNECTING TABLE	049-GRIS SEDA SILK GREY / 155- NEGRO BLACK	-	-	-
49	1	NEXT STOP	328.10.M.D	BANCO 86 C/MESA DCHO BENCH 86 W/RIGHT TABLE	049-GRIS SEDA SILK GREY / 155- NEGRO BLACK	ZERO MAUVE	11	ZERO
50	2	ESTANTE	335.84.QT	ESTRUCTURA 140X178 STRUCTURE 140X178	049-GRIS SEDA SILK GREY	-	-	-
50	8	ESTANTE	335.8A.Q.LA	140 TRASERAS Y LATERALES TEXTILES 140 UPHOL. BACK & SIDE PANELS	-	UNIFORM MEL SMOKE	8	KVADRAT FEBRIK
50	4	ESTANTE	335.8A.Q.AL	140 - 2 PUERTAS DE ALUMINIO 140 - 2 ALUMINIUM DOORS	-	-	-	-
51	1	MEETING POINT	333.15.KG	PUF 90x60 MESA D30 FRESNO POUF 90x60 TABLE D30 ASH	049-GRIS SEDA SILK GREY	6257	6	126
52	1	NEXT STOP	328.12.P	MODULO 114 MODULE 114	108 BLACK / 151-BLACK	ZERO PETROL	11	ZERO
53	1	PION PETRA	284.71.FE.A6	MESITA D50X40 TABLE D50X40	130-HIELO /IBIZA 130-ICE / IBIZA	-	-	-
54	1	INTERCHANGE	332.88.T	BANCO 178X50 BENCH 178x50	002-NATURAL	-	-	-
54	1	INTERCHANGE	332.32.G	MESITA FRESNO D60 ASH WOOD TABLE D60	055- SOMBRA SHADOW	-	-	-
54	1	INTERCHANGE	332.3Q.C	MESITA DM BRILLO 29X48 GLOSSY MDF TABLE 29X48	116-MOSTAZA MUSTARD	-	-	-
55	1	INTERCHANGE	332.88.T	BANCO 178X50 BENCH 178x50	002-NATURAL	-	-	-
55	1	INTERCHANGE	332.3R.ED	ASIENTO D46 PACK 2 SEAT D46 PACK 2	-	HALLINGDALL 65600	10	KVADRAT
55	1	INTERCHANGE	332.3R.E	ASIENTO D46 SEAT D46	-	HALLINGDALL 65596	10	KVADRAT
56	1	INTERCHANGE	332.88.T	BANCO 178X50 BENCH 178x50	108-NEGRO BLACK	-	-	-
56	1	INTERCHANGE	332.32.G	MESITA FRESNO D60 ASH WOOD TABLE D60	108-NEGRO BLACK	-	-	-
57	1	INTERCHANGE	332.88.N	BANCO 120X50 BENCH 120x50	002-NATURAL	-	-	-
57	1	INTERCHANGE	332.32.F	MESITA FRESNO 54X48 ASH WOOD TABLE 54X48	055- SOMBRA SHADOW	-	-	-
58	1	INTERCHANGE	332.88.N	BANCO 120X50 BENCH 120x50	002-NATURAL	-	-	-
58	1	INTERCHANGE	332.32.G	MESITA FRESNO D60 ASH WOOD TABLE D60	055- SOMBRA SHADOW	-	-	-
58	1	INTERCHANGE	332.3Q.C	MESITA DM BRILLO 29X48 GLOSSY MDF TABLE 29X48	129-OXIDO RUST RED	-	-	-

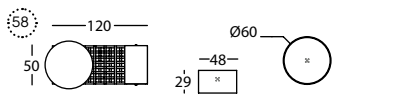
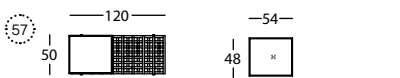
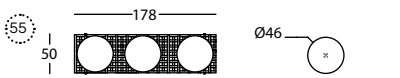
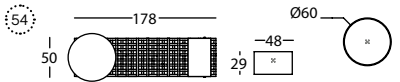
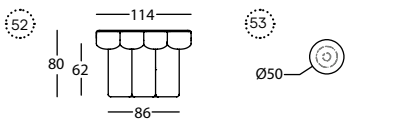
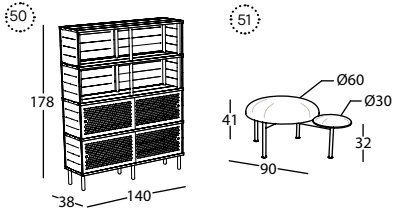
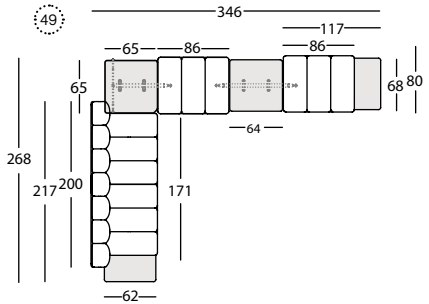
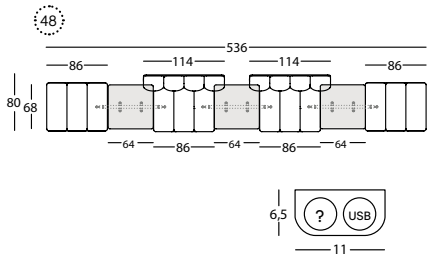

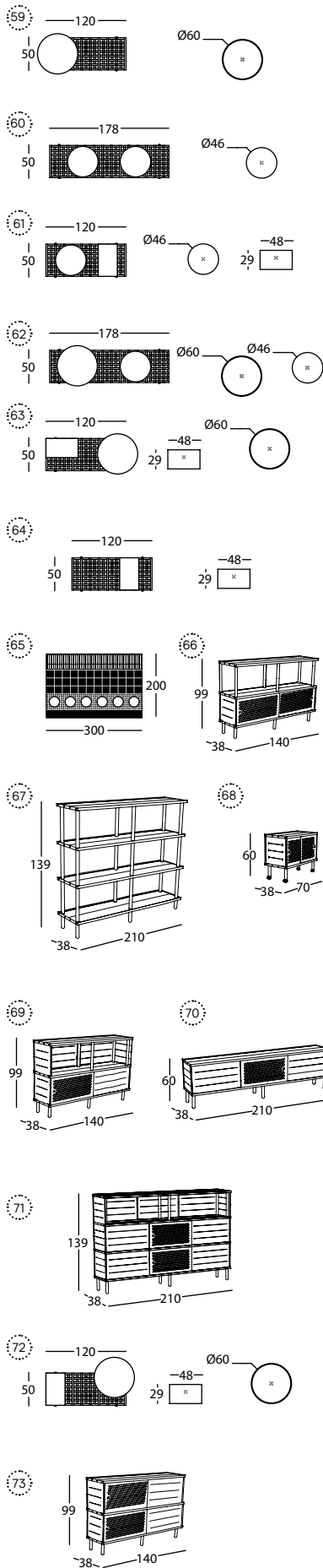

ID	UNL. QTY.	MOD.	REF.	DESCRIPCIÓN / DESCRIPTION	ACABADO FINISHES	TELAS MATERIAL	SERIES	MUESTRARIO SAMPLE BK.
59	1	INTERCHANGE	332.88.N	BANCO 120X50 BENCH 120x50	002-NATURAL	-	-	-
59	1	INTERCHANGE	332.32.G	MESITA FRESNO D60 ASH WOOD TABLE D60	043-MANGO	-	-	-
60	1	INTERCHANGE	332.88.T	BANCO 178X50 BENCH 178x50	002-NATURAL	-	-	-
60	1	INTERCHANGE	332.3R.ED	ASIENTO D46 PACK 2 SEAT D46 PACK 2	-	5005	5	122
61	1	INTERCHANGE	332.88.N	BANCO 120X50 BENCH 120x50	002-NATURAL	-	-	-
61	1	INTERCHANGE	332.3R.E	ASIENTO D46 SEAT D46	-	HALLINGDALL 65 600	10	KVADRAT
61	1	INTERCHANGE	332.3Q.C	MESITA DM BRILLO 29X48 GLOSSY MDF TABLE 29X48	129-OXIDO RUST RED	-	-	-
62	1	INTERCHANGE	332.88.T	BANCO 178X50 BENCH 178x50	002-NATURAL	-	-	-
62	1	INTERCHANGE	332.3R.E	ASIENTO D46 SEAT D46	-	5005	5	122
62	1	INTERCHANGE	332.32.G	MESITA FRESNO D60 ASH WOOD TABLE D60	108-NEGRO BLACK	-	-	-
63	1	INTERCHANGE	332.88.N	BANCO 120X50 BENCH 120x50	003-NOGAL WALNUT	-	-	-
63	1	INTERCHANGE	332.3Q.C	MESITA DM BRILLO 29X48 GLOSSY MDF TABLE 29X48	118- SOMBRA SHADOW	-	-	-
63	1	INTERCHANGE	332.32.G	MESITA FRESNO D60 ASH WOOD TABLE D60	055- SOMBRA SHADOW	-	-	-
64	1	INTERCHANGE	332.88.N	BANCO 120X50 BENCH 120x50	003-NOGAL WALNUT	-	-	-
64	1	INTERCHANGE	332.3Q.C	MESITA DM BRILLO 29X48 GLOSSY MDF TABLE 29X48	116-MOSTAZA MUSTARD	-	-	-
65	1	MIND THE GAP	334.6.WZ7.B	ALFOMBRA 200X300 NEGRO CARPET 200X300 BLACK	-	-	-	-
66	1	ESTANTE	335.84.QK	ESTRUCTURA 140X99 STRUCTURE 140X99	049-GRIS SEDA SILK GREY	-	-	-
66	1	ESTANTE	335.8A.Q.LA	140 TRASERAS Y LATERALES TEXTILES 140 UPHOL. BACK & SIDE PANELS	-	UNIFORM MEL SMOKE	8	KVADRAT FEBRIK
66	1	ESTANTE	335.8A.Q.AL	140 - 2 PUERTAS DE ALUMINIO 140 - 2 ALUMINIUM DOORS	-	UNIFORM MEL SMOKE	8	KVADRAT FEBRIK
67	1	ESTANTE	335.84.XP	ESTRUCTURA 210X139 STRUCTURE 210X139	043-MANGO	-	-	-
68	1	ESTANTE	335.84.HG	ESTRUCTURA 70X60 CON RUEDAS STRUCTURE 70X60 FEET WITH WHEELS	042-AMARILLO YELLOW	-	-	-
68	1	ESTANTE	335.8A.H.LA	70 TRASERAS Y LATERALES TEXTILES 70 UPHOL. BACK & SIDE PANELS	-	UNIFORM MEL BANANA	8	KVADRAT FEBRIK
68	1	ESTANTE	335.8A.H.AL	70 - 2 PUERTAS DE ALUMINIO 70 - 2 ALUMINIUM DOORS	-	UNIFORM MEL BANANA	8	KVADRAT FEBRIK
69	1	ESTANTE	335.84.QK	ESTRUCTURA 140X99 STRUCTURE 140X99	002-NATURAL	-	-	-
69	2	ESTANTE	335.8A.Q.LA	140 TRASERAS Y LATERALES TEXTILES 140 UPHOL. BACK & SIDE PANELS	-	UNIFORM MEL CORAL	8	KVADRAT FEBRIK
69	1	ESTANTE	335.8A.Q.MX	140-1PUERTA ALUMINIO Y 1PUERTA TEXTIL 140 - 1 ALUMINIUM & 1 UPHOLSTERED DOORS	-	UNIFORM MEL CORAL	8	KVADRAT FEBRIK
70	1	ESTANTE	335.84.XG	ESTRUCTURA 210X60 STRUCTURE 210X60	108-NEGRO BLACK	-	-	-
70	1	ESTANTE	335.8A.X.LA	210 TRASERAS Y LATERALES TEXTILES 210 UPHOL. BACK & SIDE PANELS	-	UNIFORM MEL CHALK	8	KVADRAT FEBRIK
70	1	ESTANTE	335.8A.X.MXTA	210-2PUERTAS TEXTIL 1PUERTA ALUMINIO 210 - 2 UPHOLSTERED & 1 ALUMINIUM DOORS	-	UNIFORM MEL CHALK	8	KVADRAT FEBRIK
71	1	ESTANTE	335.84.XP	ESTRUCTURA 210X139 STRUCTURE 210X139	043-MANGO	-	-	-
71	3	ESTANTE	335.8A.X.LA	210 TRASERAS Y LATERALES TEXTILES 210 UPHOL. BACK & SIDE PANELS	-	UNIFORM MEL CORAL	8	KVADRAT FEBRIK
71	2	ESTANTE	335.8A.X.MXTA	210-2PUERTAS TEXTIL 1PUERTA ALUMINIO 210 - 2 UPHOLSTERED & 1 ALUMINIUM DOORS	-	UNIFORM MEL CORAL	8	KVADRAT FEBRIK
72	1	INTERCHANGE	332.88.N	BANCO 120X50 BENCH 120x50	002-NATURAL	-	-	-
72	1	INTERCHANGE	332.32.G	MESITA FRESNO D60 ASH WOOD TABLE D60	043-MANGO	-	-	-
72	1	INTERCHANGE	332.3Q.C	MESITA DM BRILLO 29X48 GLOSSY MDF TABLE 29X48	129-OXIDO RUST RED	-	-	-
73	1	ESTANTE	335.84.QK	ESTRUCTURA 140X99 STRUCTURE 140X99	043-MANGO	-	-	-
73	2	ESTANTE	335.8A.Q.LA	140 TRASERAS Y LATERALES TEXTILES 140 UPHOL. BACK & SIDE PANELS	-	UNIFORM MEL CORAL	8	KVADRAT FEBRIK
73	2	ESTANTE	335.8A.Q.MX	140-1PUERTA ALUMINIO Y 1PUERTA TEXTIL 140 - 1 ALUMINIUM DOORS & 1 UPHOLSTERED	-	UNIFORM MEL CORAL	8	KVADRAT FEBRIK

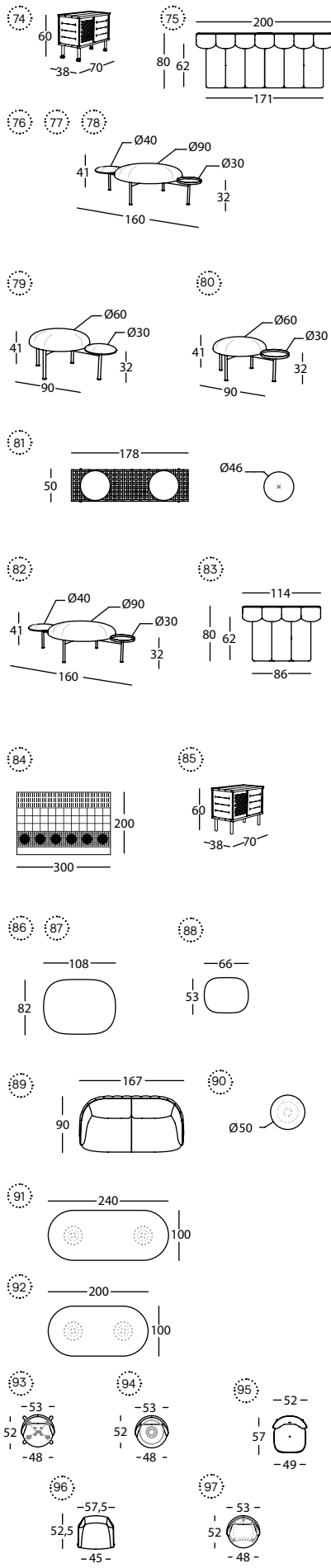

ID	UNI. QTY.	MOD.	REF.	DESCRIPCIÓN / DESCRIPTION	ACABADO FINISHES	TELAS MATERIAL	SERIES	MUESTRARIO SAMPLE BK.
74	1	ESTANTE	335.84.HG	ESTRUCTURA 70X60 CON RUEDAS STRUCTURE 70X60 FEET WITH WHEELS	042-AMARILLO YELLOW	-	-	-
74	1	ESTANTE	335.8A.H.LA	70 TRASERAS Y LATERALES TEXTILES 70 UPHOL. BACK & SIDE PANELS	-	UNIFORM MEL BANANA	8	KVADRAT FEBRIK
74	1	ESTANTE	335.8A.H.MX	70 - 1 PUERTA ALUMINIO Y 1 PUERTA TEXTIL 70 - 1 ALUMINIUM DOORS & 1 UPHOLSTERED	-	UNIFORM MEL BANANA	8	KVADRAT FEBRIK
75	1	NEXT STOP	328.12.X	MODULO 200 NOGAL MODULE 200 WALNUT	002-NATURAL / 084-CROMO CHROME	6251	6	126
76	1	MEETING POINT	333.15.S.7	PUF 160x90 MESA D30 METAL POUF 160x90 TABLE D30 METAL	002-NATURAL / 151-NEGRO BLACK	6252	6	126
77	1	MEETING POINT	333.15.S.7	PUF 160x90 MESA D30 METAL POUF 160x90 TABLE D30 METAL	049-GRIS SEDA SILK GREY / 155-ORO GOLD	PECTO 0244	9	KVADRAT FEBRIK
78	1	MEETING POINT	333.15.S.7	PUF 160x90 MESA D30 METAL POUF 160x90 TABLE D30 METAL	108-NEGRO BLACK / 151-NEGRO BLACK	MOSAIC 2 0182	8	KVADRAT FEBRIK
79	1	MEETING POINT	333.15.KG	PUF 90x60 MESA D30 FRESNO POUF 90x60 TABLE D30 ASH	108-NEGRO BLACK	6257	6	126
80	2	MEETING POINT	333.15.K.7	PUF 90x60 MESA D30 METAL POUF 90x60 TABLE D30 METAL	151-NEGRO BLACK	6252	6	126
81	2	INTERCHANGE	332.88.T	BANCO 178X50 BENCH 178x50	002-NATURAL	-	-	-
81	2	INTERCHANGE	332.3R.ED	ASIENTO D46 PACK 2 SEAT D46 PACK 2	-	SOFT 44026	12P	ELMO SOFT
82	1	MEETING POINT	333.15.S.7	PUF 160x90 MESA D30 METAL POUF 160x90 TABLE D30 METAL	049-GRIS SEDA SILK GREY / 155-ORO GOLD	PECTO 0444	9	KVADRAT FEBRIK
83	1	NEXT STOP	328.12.P	MODULO 114 NOGAL MODULE 114 WALNUT	002-NATURAL / 084-CROMO CHROME	ZERO YELLOW	11	ZERO
84	1	MIND THE GAP	334.6.WZ7.S	ALFOMBRA 200X300 PIEDRA CARPET 200X300 STONE	-	-	-	-
85	1	ESTANTE	335.84.HG	ESTRUCTURA 70X60 STRUCTURE 70X60	042-AMARILLO YELLOW	-	-	-
85	1	ESTANTE	335.8A.H.LA	70 TRASERAS Y LATERALES TEXTILES 70 UPHOL. BACK & SIDE PANELS	-	UNIFORM MEL BANANA	8	KVADRAT FEBRIK
85	1	ESTANTE	335.8A.H.MX	70 - 1 PUERTA ALUMINIO Y 1 PUERTA TEXTIL 70 - 1 ALUMINIUM DOORS & 1 UPHOLSTERED	-	UNIFORM MEL BANANA	8	KVADRAT FEBRIK
86	1	TONELLA	301.15.LJ	PUF 108X82 POUF 108X82	103-NACAR	8067	7	116
87	1	TONELLA	301.15.LJ	PUF 108X82 POUF 108X83	103-NACAR	FACET 1001	4	107.2
88	1	TONELLA	301.15.GF	PUF 66X53 POUF 66X53	103-NACAR	ATLANTIC 64093	2	112 (ATLANTIC)
89	1	TONELLA	301.61.T	SOFA 167 ACOLCHADO QUILTED SOFA 167	104-BRONCE BRONZE	6114	6	115
90	1	PION PETRA	284.71.FG.A6	MESITA D50X60 TABLE D50X60	130-HIELO / IBIZA 130-ICE / IBIZA	-	-	-
91	1	PION PETRA	284.74.ZLH.A6	MESA 240X100X74 TABLE 240X100X74	SOMBRA / OCHAVO SHADOW / OCHAVO	-	-	-
92	1	PION PETRA	284.74.WLH.A6	MESA 200X100X74 TABLE 200X100X75	130-HIELO / IBIZA 130-ICE / IBIZA	-	-	-
93	1	MAGNUM	311.41.6	SILLA PATAS MADERA CHAIR WITH WOODEN FEET	049-GRIS SEDA SILK GREY	FACET 1000	4	107.2
94	1	MAGNUM	311.47	SILLA PIE CENTRAL LACADO CHAIR LACQ. CENTRAL LEG	049-GRIS SEDA SILK GREY	ATLANTIC 60011	2	112 (ATLANTIC)
95	1	MULLIT	320.41.7	SILLA PATA METAL CHAIR WITH METAL FEET	151-NEGRO BLACK	6115	6	115
96	1	NIDO	288.41.7	SILLA PATA METAL C/VIVO DINING CH. METAL FEET & PIPING	151-NEGRO BLACK	6111	6	115
97	1	MAGNUM	311.41	SILLA BASE TAPIZADA CHAIR WITH UPHOLSTERED BASE	-	5002	5	122

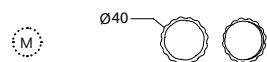
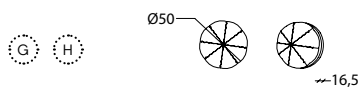
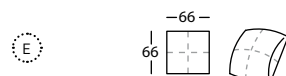
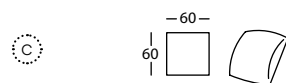
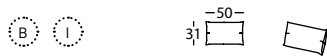
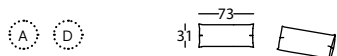

ID	UNI. QTY.	MOD.	REF.	DESCRIPCIÓN / DESCRIPTION	ACABADO FINISHES	TELAS MATERIAL	SERIES	MUESTRARIO SAMPLE BK.
A	1	ALPINO	331.22.HD	COJIN 73X31 CUSHION 73X31	-	PLECTO 0444	9	KVADRAT FEBRIK
B	1	ALPINO	331.22.FD	COJIN 50X31 CUSHION 50X31	-	5605	5	122
C	1	C1-C4	310.22.C4L	C1-C4 COJIN 58X58 - C4 LANA C1-C4 CUSHION 58X58 - C4 WOOL	-	-	-	-
D	1	ALPINO	331.22.HD	COJIN 73X31 CUSHION 73X31	-	ATLANTIC 63057	2	112 (ATLANTIC)
E	1	COJÍN	100.22.GG	COJIN FINO DECORACIÓN 66X66 FLOPPY CUSHION 66X66	-	2810	3	118
F*	1	RIFT	324.22.EE.C2	COJIN 40X40 TEJA CUSHION 40X40 BRICK-RED	-	7203	7	124 (RIFT)
G	1	MANDARINA	267.24.F.O	COJIN D50X16.5 FRUNCIDO WINKLED CUSHION D50X16.5	-	62057	3	108
H	1	MANDARINA	267.24.F.O	COJIN D50X16.5 FRUNCIDO WINKLED CUSHION D50X16.5	-	ATLANTIC 62049	2	112 (ATLANTIC)
I	1	ALPINO	331.22.FD	COJIN 50X31 CUSHION 50X31	-	PLECTO 0444	9	KVADRAT FEBRIK
J*	1	RIFT	324.22.EE.C3	COJIN 40X40 AMARILLO CUSHION 40X40 YELLOW	-	7200	7	124 (RIFT)
K*	1	RIFT	324.22.DD.C3	COJIN 30X30 AMARILLO CUSHION 30X30 YELLOW	-	7200	7	124 (RIFT)
L*	1	FLORA & FAUNA	323.22. EE.WD01	COJIN 40X40 - WILD DOTS 01 / PELO NARANJA CUSHION 40X40 - WD01 / ORANGE FUR	-	-	-	-
M	1	BANG!	299.22.E.4	COJIN D40 PERLA CUSHION D40 PEARL	-	3869 / CODA 232	-	102 / KVADRAT
N	1	COJÍN	100.22.CC	COJIN 30X30 CUSHION 30X30	-	7204	7	124 (RIFT)
Ñ	1	COJÍN	100.22.CC	COJIN 30X30 CUSHION 30X31	-	STEP 65018	3	108 (STEP)

* Los accesorios de éste catálogo pertenecen a **COSAS**, la gama de objetos lifestyle que **Sancal** ha creado para hacerte feliz.

* This catalogue features Sancal **COSAS**, a range of accessories designed in Spain with love.

Info: www.sancal.com/cosas

SANCAL REF. 19011_TURATI_COLLECTION

SANCAL DISEÑO, S.L.
Pol. Ind. La Herrada C/ Príncipe de Asturias, 18
30510 Yecla (Murcia) Spain
Tel Esp. +34 968 75 15 03
Tel. Eng. +34 968 71 90 62
Tel. Fra. +34 968 71 90 61
Fax +34 968 79 40 62
e-mail web@sancal.com
www.sancal.com

Art direction & styling Juan Ibáñez & Elena Castaño-López
Photography Marcelo Martínez
Coordination Esther Castaño-López
Graphic project Juan Ibáñez & Sonia Marco

Copyright © Sancal Diseño S.L. 2019



Nº depósito legal MU 664-2019

Print Vanguard



