

HermanMiller
Ergonomic Solutions

2013 Catalogue



For you. Because you're unique.

You're wonderfully one-of-a-kind in the way your body,
eyes, and brain work.



The background features a repeating pattern of white geometric shapes on a light gray background. The shapes include circles, squares, and quarter-circles, some of which are partially cut off by the edges of the frame. The arrangement is somewhat irregular, creating a modern, minimalist aesthetic.

And so are we.

A long tradition of thought leadership. A history of firsts. And the biggest portfolio of ergonomic and technology support products in the world. Whoever you are, we're here to help you thrive.

Our knowledge goes way back.

Our products, way ahead.

Ergonomic Solutions comes from a long line of innovators, design experts, and award winners. Years of studying how people work have produced a string of firsts that help people feel better and work better. And there are plenty more where those came from.

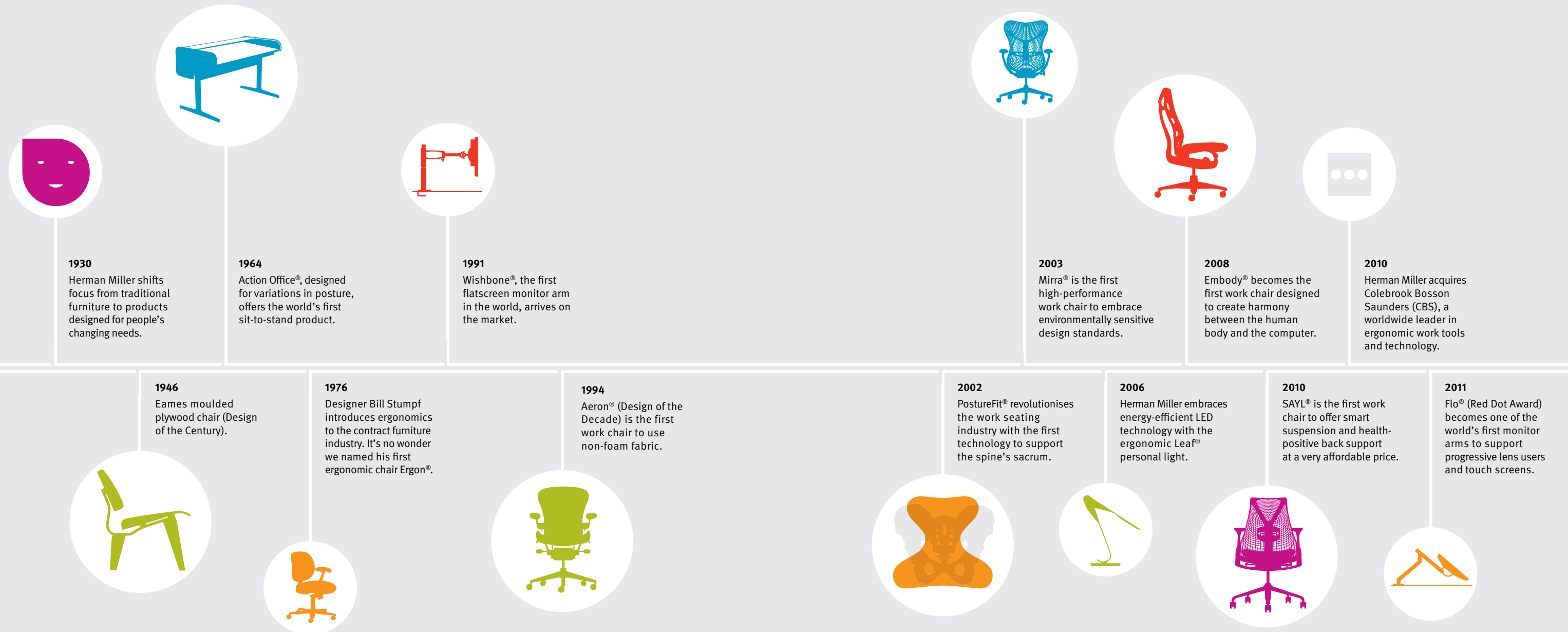



The personal workspace is getting smaller.
The role of technology is getting bigger.
And in the middle of it all is your company's
greatest asset: you.

Herman Miller values your comfort, health,
and productivity just as highly as you
do. That's why we've designed a whole
portfolio of products that work in harmony
to keep people feeling and performing
their best. When it all comes together,
everyone can thrive.

YOU SIT MORE THAN YOU SLEEP.

A comfortable bed is important for your body, but studies show you actually spend more time in your chair. At Herman Miller, we understand how much sitting asks of our bodies, and we've designed the most innovative chairs on earth to meet those needs. Millions of people spend the majority of their day with us. Now it's your turn to try our chairs, too.

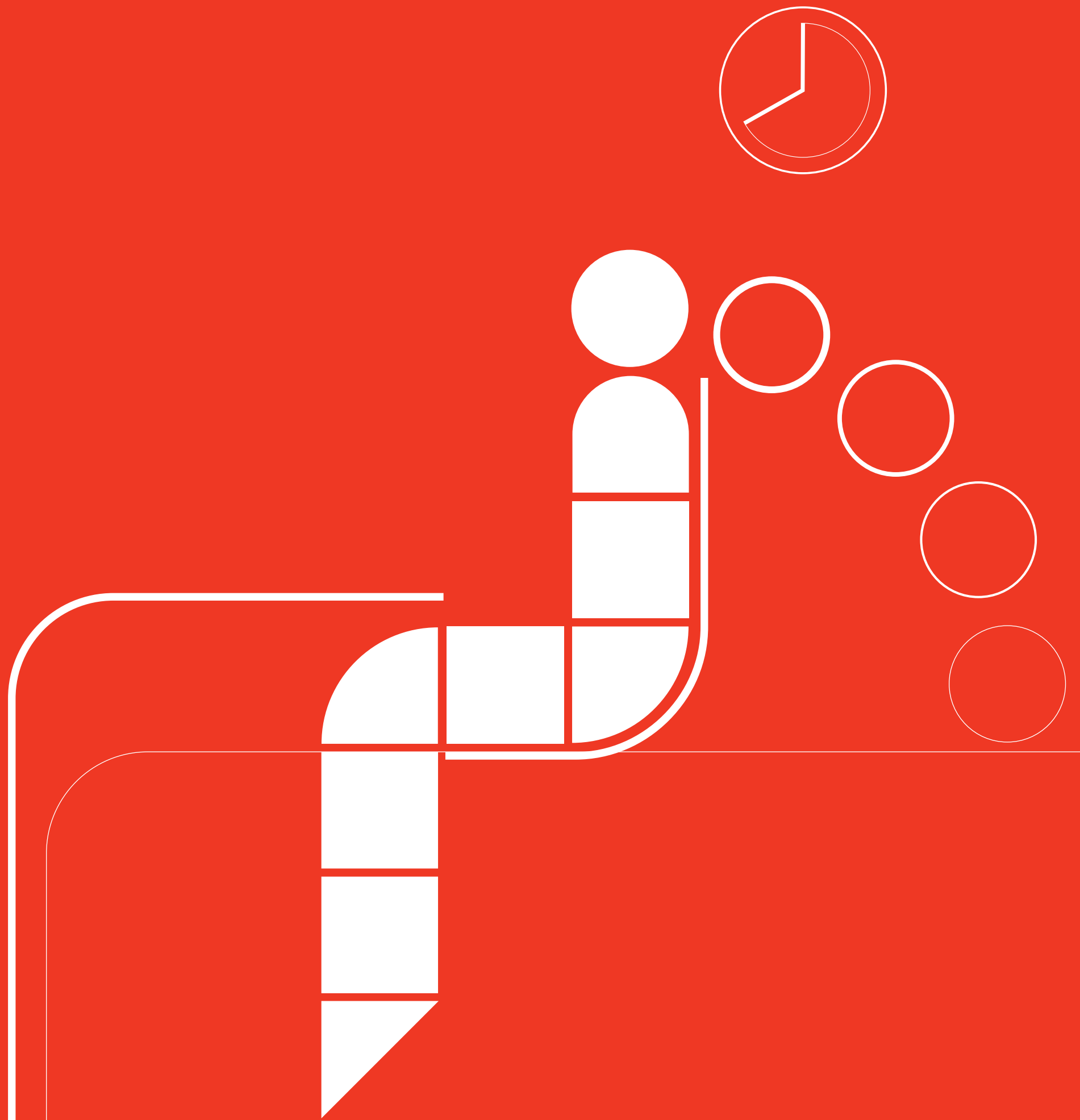

Work Chair
Aeron®

It's the first ergonomic work chair to replace upholstery with breathable, form-fitting suspension that adapts to virtually every body and keeps you cool and focused.

How It Works For You

Patented, breathable Pellicle® suspension material lets heat and moisture dissipate while giving your body dynamic support.

PostureFit sacral support aligns your lower back in a health-positive position, decreasing muscle fatigue and improving endurance during long periods of sitting.

The chair's tilt design mimics the body's natural pivot points at the hips, knees, and ankles, supporting you naturally from an upright to fully reclined position.

Designers

Bill Stumpf and Don Chadwick

Warranty

12-years, 24/7



Seating

Reinventing Support

Named the Design of the Decade in 1999, Aeron changed the way everyone thought about office chairs—from its revolutionary look to its advanced ergonomics to the fact that it's 94 percent recyclable. Aeron's iconic design and stay-cool Pellicle suspension instantly turned heads and won hearts. Its distinctive style earned a place in MOMA's permanent collection (and many of yours, too).

Work Chair
Embod^y

The first work chair specifically designed to create harmony between you and your technology. Embod^y keeps you alert, keeps you aligned, and keeps your blood and creative juices flowing.

How It Works For You

The seat and back form a dynamic surface that stimulates blood and oxygen flow by reducing seated pressure; all that oxygen helps you think better.

The chair back adjusts instinctively to every move you make and keeps support of your lower back constant.

Embod^y keeps you in a neutral, balanced posture as you work, so you stay relaxed and focused.

Designers

Bill Stumpf and Jeff Weber

Warranty

12-years, 24/7



Work Chair
Mirra[®]

Mirra naturally fits active workers in today's evolving environments. It supports a wide range of people and applications with a highly responsive design.

How It Works For You

You get support and flexibility from the one-piece back, which fits individual sizes and supports the way you move.

PostureFit sacral support keeps your lower back properly aligned.

AireWeave™ suspension seat distributes your body weight evenly and keeps you cool.

Designers

Studio 7.5

Warranty

12-years, 24/7



Bye-Bye, Back Pain

Research shows that slouching contributes to fatigue, backaches, headaches, and sometimes more serious health problems on the job. With PostureFit, you sit better, so you feel better and work better. Isn't that how it should be?



Inspired by Suspension

Designer Yves Béhar began his research into a new work chair by looking at examples of design that deliver the most with the least. He wondered: Can the same principles that suspend a bridge over water be applied to a chair? The answer was yes, and the result is SAYL. Its suspended, frameless back encourages healthy movement.

Work Chair **SAYL®**

When you settle into the frameless back of a SAYL chair, you experience unprecedented freedom of movement and beautiful support.

How it works for you

The suspension back has support moulded in, eliminating hard edges and the need for a frame.

Flexible elastomer back adapts to each person's unique shape and provides exceptional comfort and support for just about all body types.

Mix colors on the seat, back, and arm pads for a bold look, or match them for a more traditional appearance.

Designer

Yves Béhar

Warranty

12-years, 24/7



Work Chair **Celle**[®]

This chair is the perfect combination of innovative support, great looks, and more comfort than any other work chair in its price category.

How it works for you

Cellular Suspension™ system is available in the seat and back, and provides the perfect flex map for supporting your body.

Suspension also lets air flow through, so skin temperature remains constant.

PostureFit sacral support aligns your lower back in a health-positive position, decreasing muscle fatigue and improving endurance during long periods of sitting.

Harmonic™ tilt design mimics your natural movements from upright to fully reclined.

Designer

Jerome Caruso

Warranty

12-years, 24/7



Multipurpose Chair **Setu**[®]

The sophisticated design complements all of the places you meet and sit. Adjustments are simple—your weight controls how the chair moves and conforms to your body.

How it works for you

Innovative Kinematic Spine™ bends and flexes automatically with your every move.

Elastomeric material offers superior suspension while conforming to your contours.

Five-star base provides stability while working and has casters to keep you mobile.

Designer

Studio 7.5

Warranty

12-years, 24/7



Backed by Science

Herman Miller seating is recognised for its distinctive design, but it's the science behind our seating that creates that "WOW" experience every time you sit down.

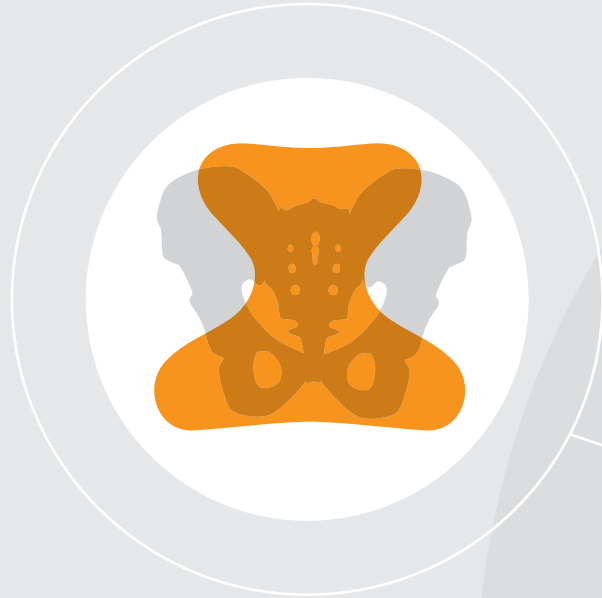

PostureFit

We've built our game-changing PostureFit sacral support into the seat back of every work chair since Aeron. Most work chairs focus only on the lumbar region, but PostureFit starts at the base (sacrum) of the spine—which research shows must be supported to keep the rest of your spine properly aligned. It's this support that makes such a difference in the way you feel, promoting healthy blood and oxygen flow and preventing back and neck pain.



Balance and Motion

The balance and smoothness of our tilt performance is unparalleled in the industry. We've designed it to mimic the movement of the human body, helping all our work chairs support you in every position from upright to fully reclined.



Material Innovations

From Pixelated Support™ in the Embody chair to Kinematic Spine and Lyris™ suspension in the Setu chair, our material innovations create dynamic and personalised support for you. The seats and backs of our chairs conform to your body, providing ideal support while eliminating pressure points and keeping you cool throughout the day.

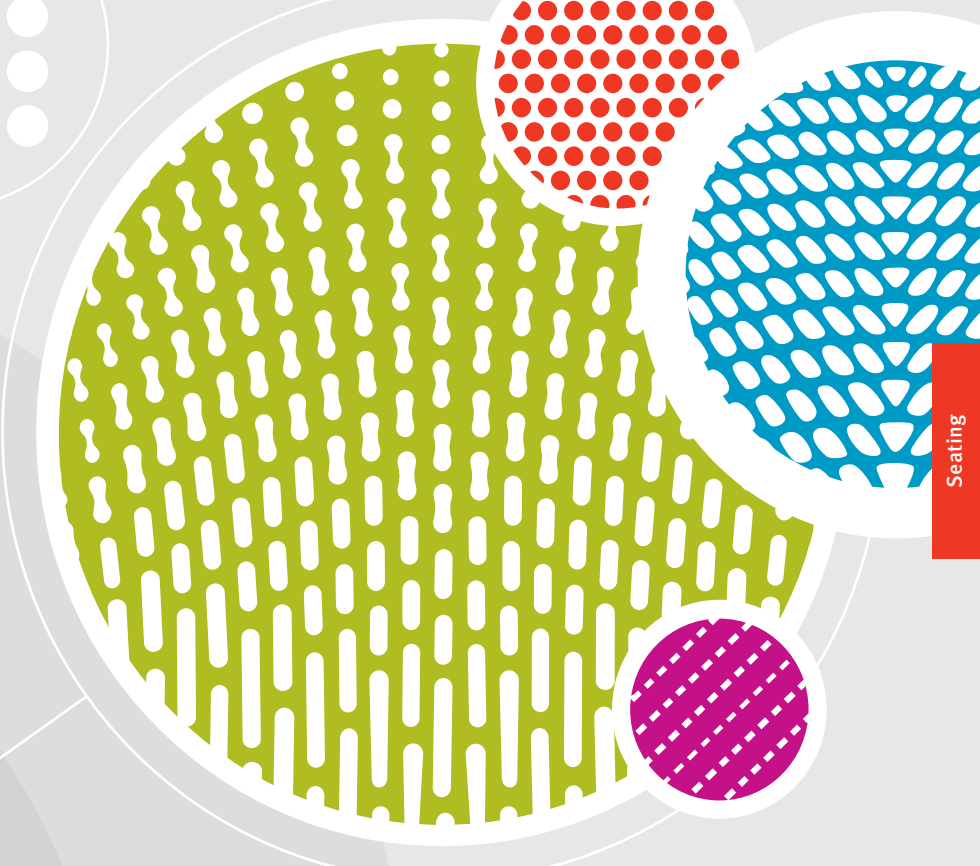

Comparing Chairs

What's important to you? Whatever it is, we have just the seat to fit the bill.



Embody

Aeron

Mirra

Celle

SAYL

Setu

| | Embody | Aeron | Mirra | Celle | SAYL | Setu | |
|-----------------------------------|--|----------------|-----------------------|------------------------|------------------------|----------------|----------------|
| User Needs | Population Range | 2nd–98th | 1st–99th | 5th–95th | 5th–95th | 5th–98th | |
| | Maximum User Weight | 300lbs / 136kg | 300lbs / 136kg | 300lbs / 136kg | 350lbs / 159kg | 350lbs / 159kg | 300lbs / 136kg |
| | Ergonomic Support Rating | ●●●● | ●●●● | ●●●● | ●●●● | ●●●● | ●●●● |
| | Thermal Comfort Rating | ●●●● | ●●●● | ●●●● | ●●●● | ●●●● | ●●●● |
| Ergonomic Highlights | Height Range | 432–559mm | 366mm–528mm | 406mm–546mm | 419mm–540mm | 419mm–559mm | 445mm–551mm |
| | Adjustable Seat | ● | | ● | ● | ● | |
| | Adjustable Arms | ● | ● | ● | ● | ● | |
| | Adjustable Lumbar Support | ● | ● | ● | ● | ● | |
| | Tilt Mechanism | Synchronous | Synchronous (Kinemat) | Synchronous (Harmonic) | Synchronous (Harmonic) | Synchronous | |
| | PostureFit | ● | ● | ● | ● | ● | |
| Vocabulary | Work Chair | ● | ● | ● | ● | | |
| | Multipurpose | | | | | ● | |
| | Side Chair | | ● | | ● | | |
| | Stool | | ● | ● | | | |
| Design for the Environment | Recyclable | 95% | 94% | 97% | 98% | 91% | 96% |
| | Cradle to Cradle Certified ^{CM} | Silver | Silver | Gold and Silver | Silver | Silver | Silver |
| | GREENGUARD [®] | Certified | Certified | Certified | Certified | Certified | Certified |
| | | 3 | 3 | 3 | 3 | 3 | 3 |

CONSIDER CHANGING YOUR POSITION ON THIS.

Your body's not designed to stay in one place all day. So if you have to sit, you need a chair that lets you move naturally. And if you can switch between sitting and standing, even better. Fewer aches and pains, fewer doctor visits and happier employees. Performance tables give you lots to feel good about.

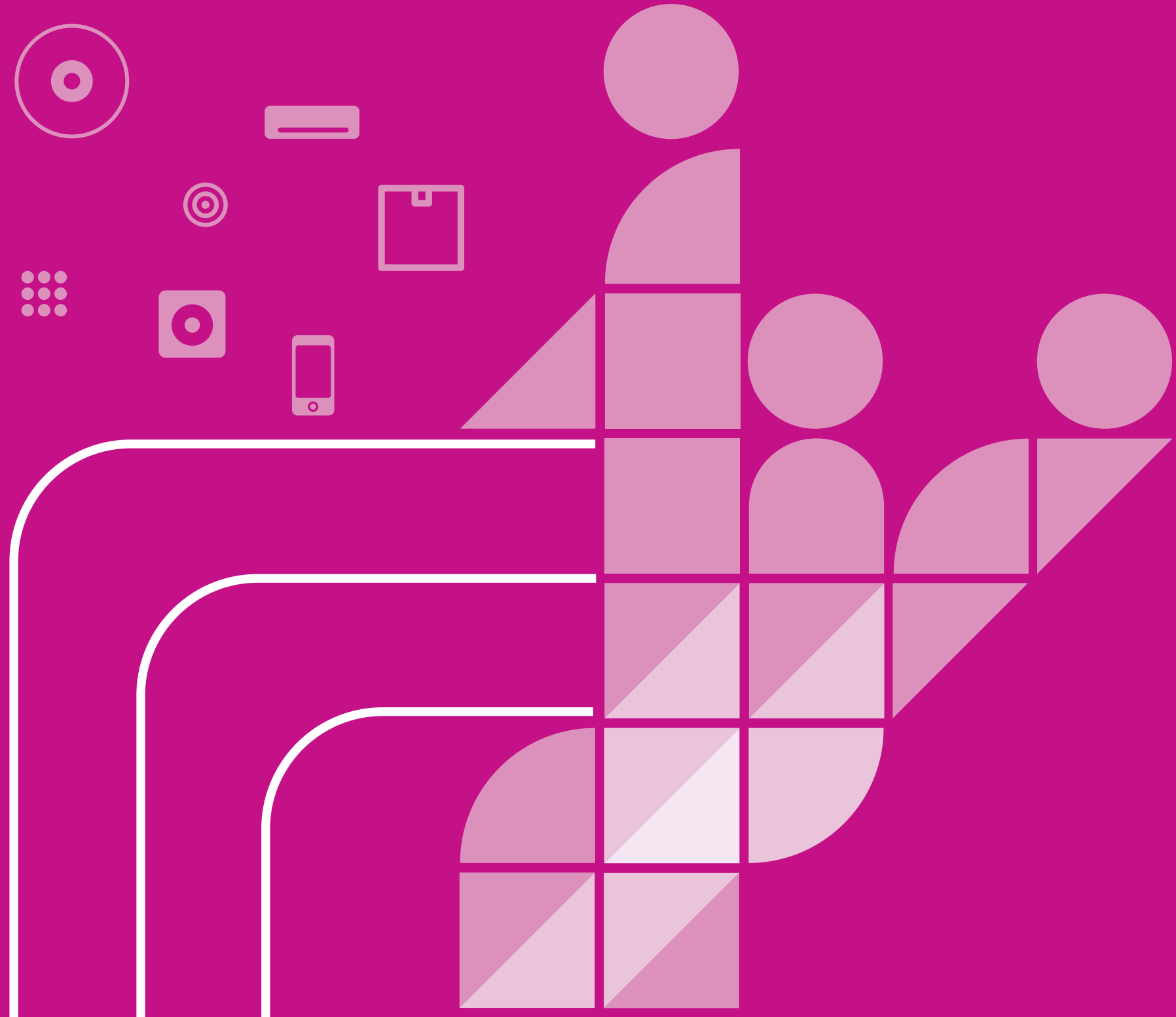



Sit. Stand. Repeat.

The healthiest posture is one that changes throughout the day. Our Alvar Lite height adjustable tables make it easy to switch between sitting and standing, encouraging movement to make your body happy.

Performance Tables

Alvar Lite

Alvar Lite is a range of height-adjustable desks, designed to cater for both sitting and standing use; a freestanding desk that can be used on its own or with other Herman Miller products.

How it works for you

Fixed, incremental pin, crank or electric options offer height adjustment to suit everyone.

The electric option worktop adjusts from 600 to 1250mm, meaning it reaches both lower and higher than the ISO standard.

There is a choice of five desk styles: rectangular, single wave, double wave, 90 corners and 120 corners

Designer

Herman Miller

Warranty

12-years, 24/7



Performance Tables

Everywhere Tables

Fine lines, simple aesthetics, and multiple options make Everywhere tables a workplace chameleon, ready to look just right in any environment.

How it works for you

Choose from multiple top shapes, leg styles, and finishes for a custom look.

Available with casters to rearrange fast. Use for meetings, training, a mobile work surface—or all of the above.

Optional flip tops let you nest tables for efficient storage.

Designer

Dan Grabowski

Warranty

12-years, 24/7



Endless Possibilities

Pick your shape, size, finish, and leg style. You name it, Everywhere has it.





Accents for Everywhere

Outfit your Everywhere tables with monitor supports and lighting that adjust to your body's needs. Power/data, cable troughs, and modesty panels add versatility.



WHAT'S TECHNOLOGY TURNING YOU INTO?

The “turtle” is just one of the awkward positions you can get into when technology gets out of line with your body. Using technology support tools like monitor and tablet supports can change that, keeping you in harmony with all sorts of equipment and whatever device is invented next. All you need are a few simple adjustments to take control and feel human again.





Anywhere You Want It

Everyone's eyes are different, but everyone's solution for the ideal monitor placement can be the same. The entire Flo family is designed with smooth, intuitive adjustments that let you choose the vertical, horizontal, and tilt position you need to reduce eyestrain and encourage healthy sitting positions—making it a truly dynamic support.

Dynamic Monitor Supports
Flo®

The range of motion and fluid, intuitive adjustments of the award-winning Flo are unsurpassed. Its patented geometric Flo Spring Technology and dynamic fingertip control let you put your screen exactly where you want it with a minimum of effort and a maximum of precision. Unlike any other product on the market, it supports everyone's eyes, even those with progressive lenses.

How it works for you

Effortlessly rotates between portrait and landscape orientations.

Patented geometric Flo Spring Technology holds any position.

Mounts easily and allows easy installation/removal of monitors.

Designer

Colebrook Bosson Saunders

Warranty

12-years, 24/7

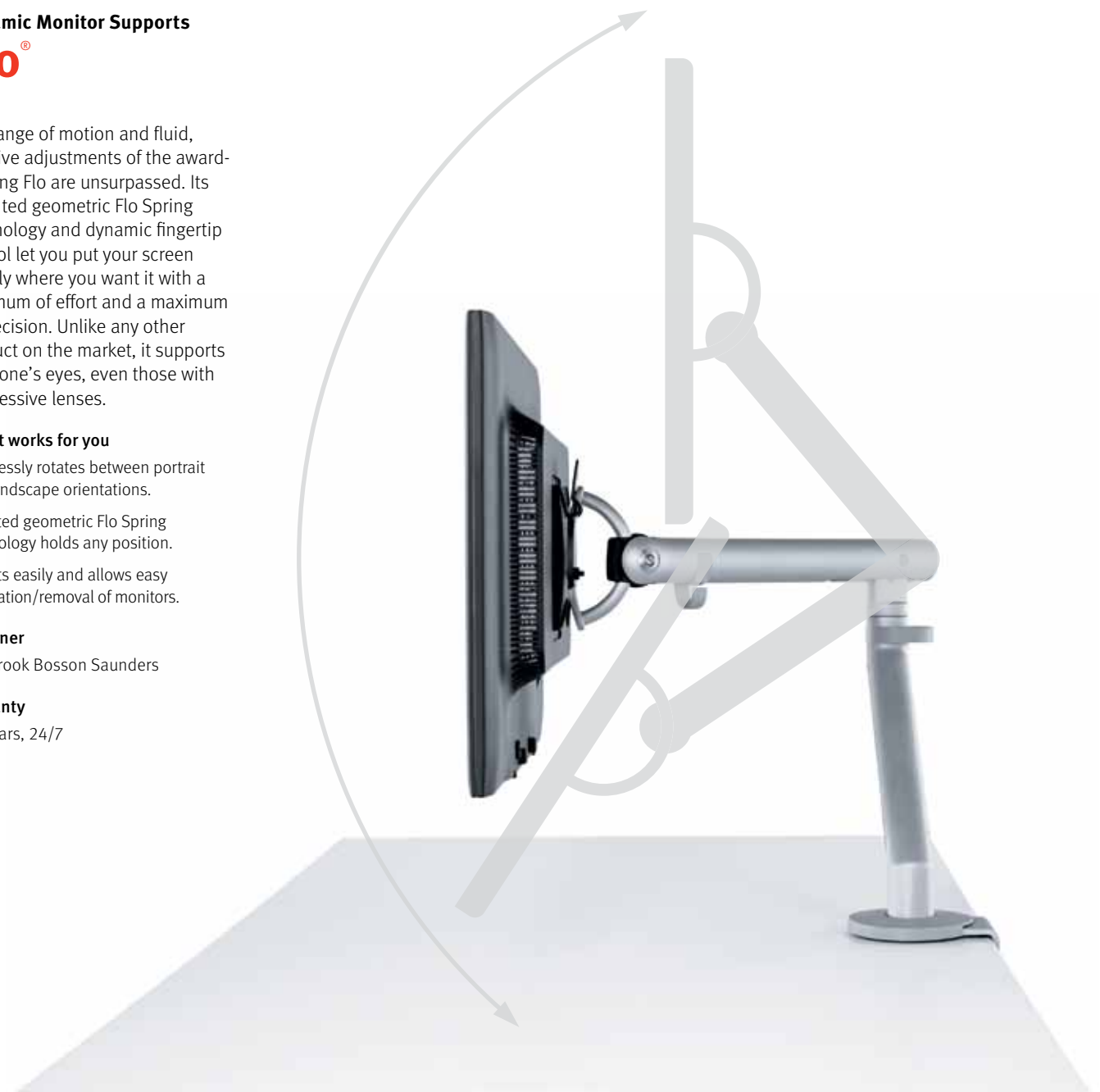

Technology Support

Monitor Configurations



1 Monitor



1 Laptop



1 Tablet

Dynamic Monitor Supports

Flo Dual

A version of the award-winning Flo monitor arm, Flo Dual supports two screens from a single clamp, allowing smooth, intuitive adjustments of each monitor.

How it works for you

Uses Flo's patented geometric spring technology for effortless adjustment to any position (landscape or portrait). Mounting and installing/removing monitors are simple.

Designer

Colebrook Bosson Saunders

Warranty

12-years, 24/7



Monitor Configurations



1 Monitor

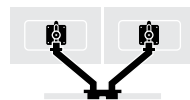

2 Monitors

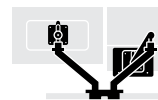

1 Monitor, 1 Laptop

Dynamic Monitor Supports

Flo Plus Single

A heavy-duty version of the award-winning Flo monitor arm, Flo Plus offers smooth, intuitive adjustment of monitors or all-in-one computers up to 18 kgs.

How it works for you

Uses Flo's patented geometric spring technology for effortless adjustment to any position (landscape or portrait). Mounting and installing/removing monitors are simple.

Designer

Colebrook Bosson Saunders

Warranty

12-years, 24/7



Monitor Configurations



1 Monitor or all-in-one

Dynamic Monitor Supports

Flo Plus Dual

Robustly engineered like Flo Plus, Flo Plus Dual uses a crossbar design with a handle to allow smooth, intuitive, and precise adjustments of two large or heavy screens (up to 18kgs total weight) moving in tandem.

How it works for you

Uses Flo's patented geometric spring technology for effortless adjustment to any position (landscape or portrait). Mounting and installing/removing monitors are simple.

Designer

Colebrook Bosson Saunders

Warranty

12-years, 24/7



Dynamic Monitor Supports

Flo Slatwall Mount

Compatible with most Herman Miller tile systems, this version of the award-winning Flo monitor support features a horizontal arm to let users adjust the height, tilt, and focal length of monitors up to 9kgs.

Designer

Colebrook Bosson Saunders

Warranty

12-years, 24/7

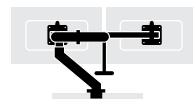

2 Monitors



Twice as Nice

Adding a second screen can boost your productivity by up to 40%.

Monitor Supports **Rodney®**

The Rodney monitor arm is an award-winning ergonomic alternative to an immobile monitor stand. Its streamlined design features one piece that functions as both post and monitor arm and holds up to 8.5kgs.

Designer

Colebrook Bosson Saunders

Warranty

12-years, 24/7



Monitor Support Attachments

Laptop Mount

The Laptop Mount lifts notebook computers off the work surface, allowing workers to adopt better postures and avoid eyestrain while clearing valuable desk space.

Designer

Colebrook Bosson Saunders

Warranty

12-years, 24/7



Mobile Support **Laptop Stand®**

The Laptop Stand lets you put your laptop or tablet at a healthy ergonomic height that reduces eye, back, and neck strain, in the home office or on the road. Designed to be used with a separate mouse and keyboard. Folds flat to carry.

Designer

Colebrook Bosson Saunders

Warranty

12-years, 24/7



Monitor Support Attachments **Tablet Mount**

The Tablet Mount moves mobile technology off the work surface, placing it at the correct height and angle to minimise eyestrain and using a locking mechanism to secure it when you step away from your desk.

Designer

Colebrook Bosson Saunders

Warranty

12-years, 24/7



Comparing Dynamic Supports

It's your technology. Your work style. And now, your well-informed choice.

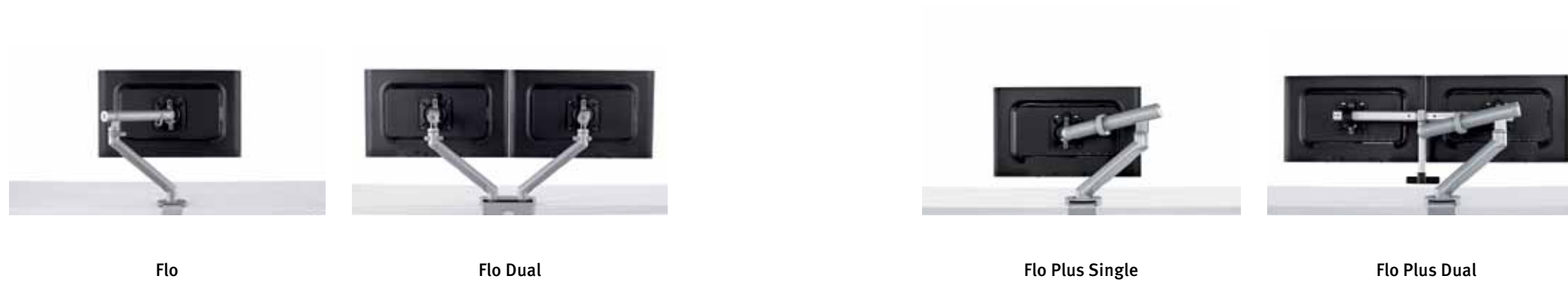

| | Flo | Flo Dual | Flo Plus Single | Flo Plus Dual |
|-----------------------------------|--|-------------------------|-------------------------|---------------|
| User Needs | Single | • | • | • |
| | Dual | | | • |
| | Triple | | | |
| | Quad | | | |
| Ergonomic Highlights | Vertical Adjustment | 343mm | 343mm | 330mm |
| | Horizontal Adjustment | 523mm | 523mm | 591mm |
| | Tilt Range | +/- 40° | +/- 40° | +/- 35° |
| | Swivel Range | 180° | 180° | 180° |
| Specs | Maximum Monitor Weight | 20lbs / 9kg | 20lbs / 9kg | 40lbs / 18kg |
| | Minimum Monitor Weight | 6lbs / 2.7kg | 6lbs each / 2.7kg each | 13lbs / 5.9kg |
| | Scalable Solution | | | • |
| | Adjustability | Dynamic | Dynamic | Dynamic |
| | Attachments | Monitor/Tablet / Laptop | Monitor/Tablet / Laptop | Monitor |
| Design for the Environment | Recyclable | 100% | 100% | 100% |
| | Pre-Consumer Content | 20% | 23% | 19% |
| | Post-Consumer Content | 23% | 21% | 17% |
| | Cradle to Cradle Certification ^{CM} | Silver | | |
| | GREENGUARD® | • | • | • |

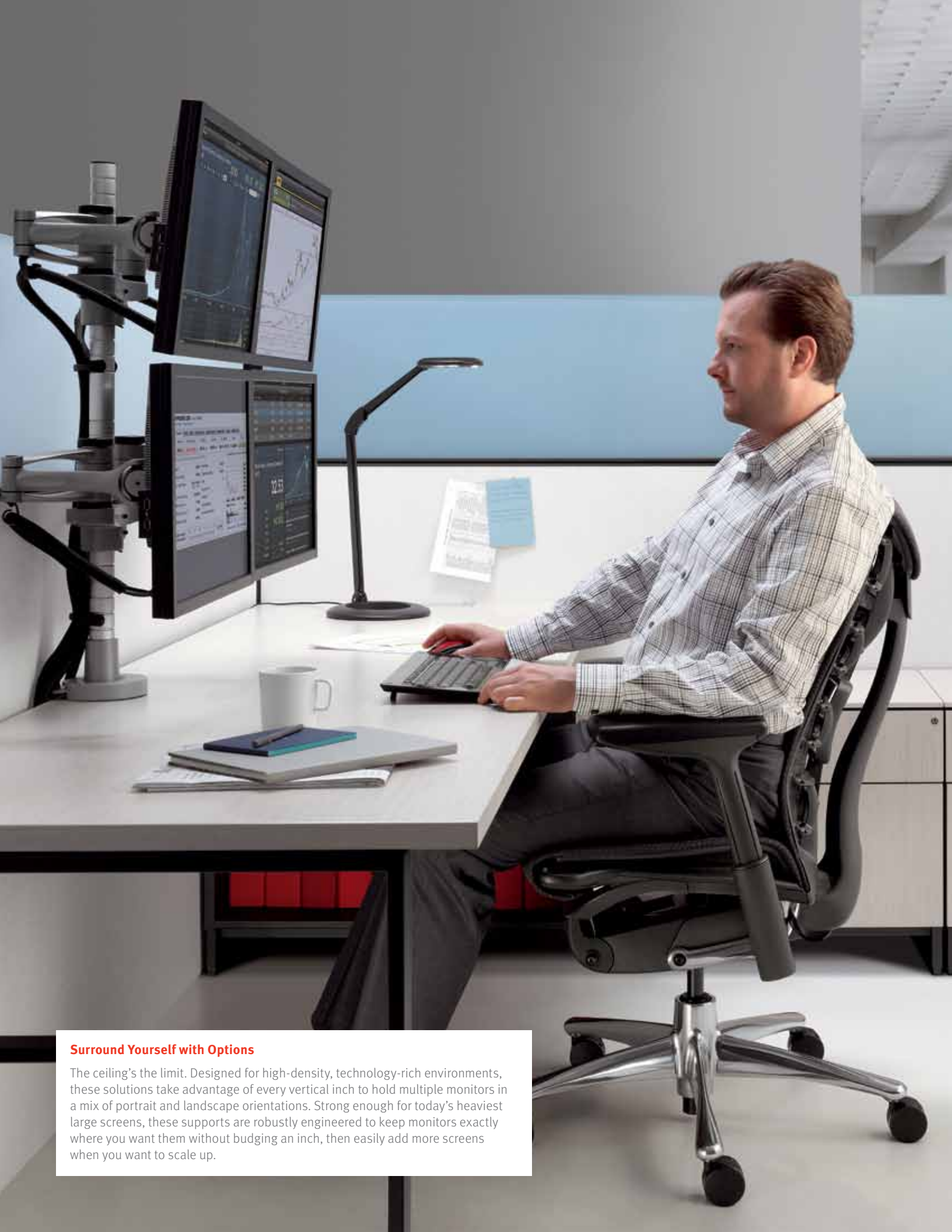

Surround Yourself with Options

The ceiling's the limit. Designed for high-density, technology-rich environments, these solutions take advantage of every vertical inch to hold multiple monitors in a mix of portrait and landscape orientations. Strong enough for today's heaviest large screens, these supports are robustly engineered to keep monitors exactly where you want them without budging an inch, then easily add more screens when you want to scale up.

High-Density Monitor Supports **Wishbone®**

Wishbone's scalable design keeps your options open, adding multiple monitors to a single post as your needs evolve. Its streamlined design frees space on your work surface while positioning your screen at the proper distance to ease neck and eye strain.

How it works for you

Allows you to create multi-screen environments.

Quick release allows monitor to be removed in seconds.

Designer

Colebrook Bosson Saunders

Warranty

12-years, 24/7



Monitor Configurations

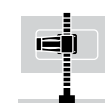

1 Monitor

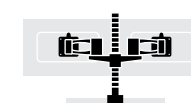

2 Monitors

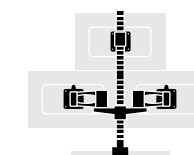

3 Monitors

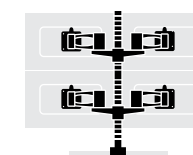

4 Monitors

High-Density Monitor Supports

Wishbone® Plus

The Wishbone Plus offers similar articulation as the standard Wishbone, but is sturdy enough to support heavier displays.

How it works for you

Supportive and adaptive allowing for productive multi-screen environments.

Fine height adjustment aligns adjacent monitors.

Rotates effortlessly between portrait and landscape orientation.

Designer

Colebrook Bosson Saunders

Warranty

12-years, 24/7

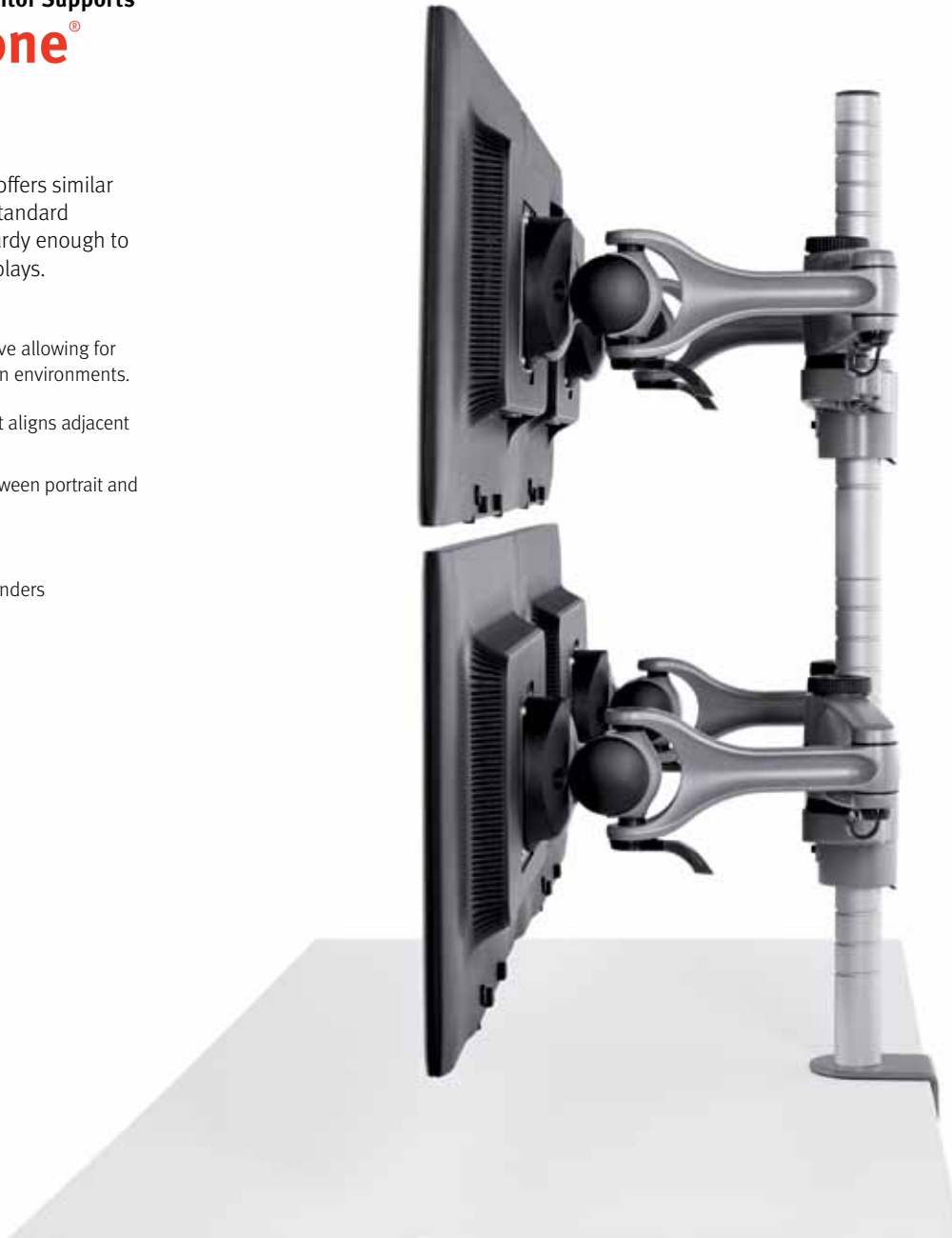

High-Density Monitor Supports

Daisyone®

Daisyone allows two flat screen monitors to be mounted at the same height on a single post without additional brackets.

How it works for you

Quick release for rapid installation and removal.

Add additional monitor without adding brackets.

Designer

Colebrook Bosson Saunders

Warranty

12-years, 24/7

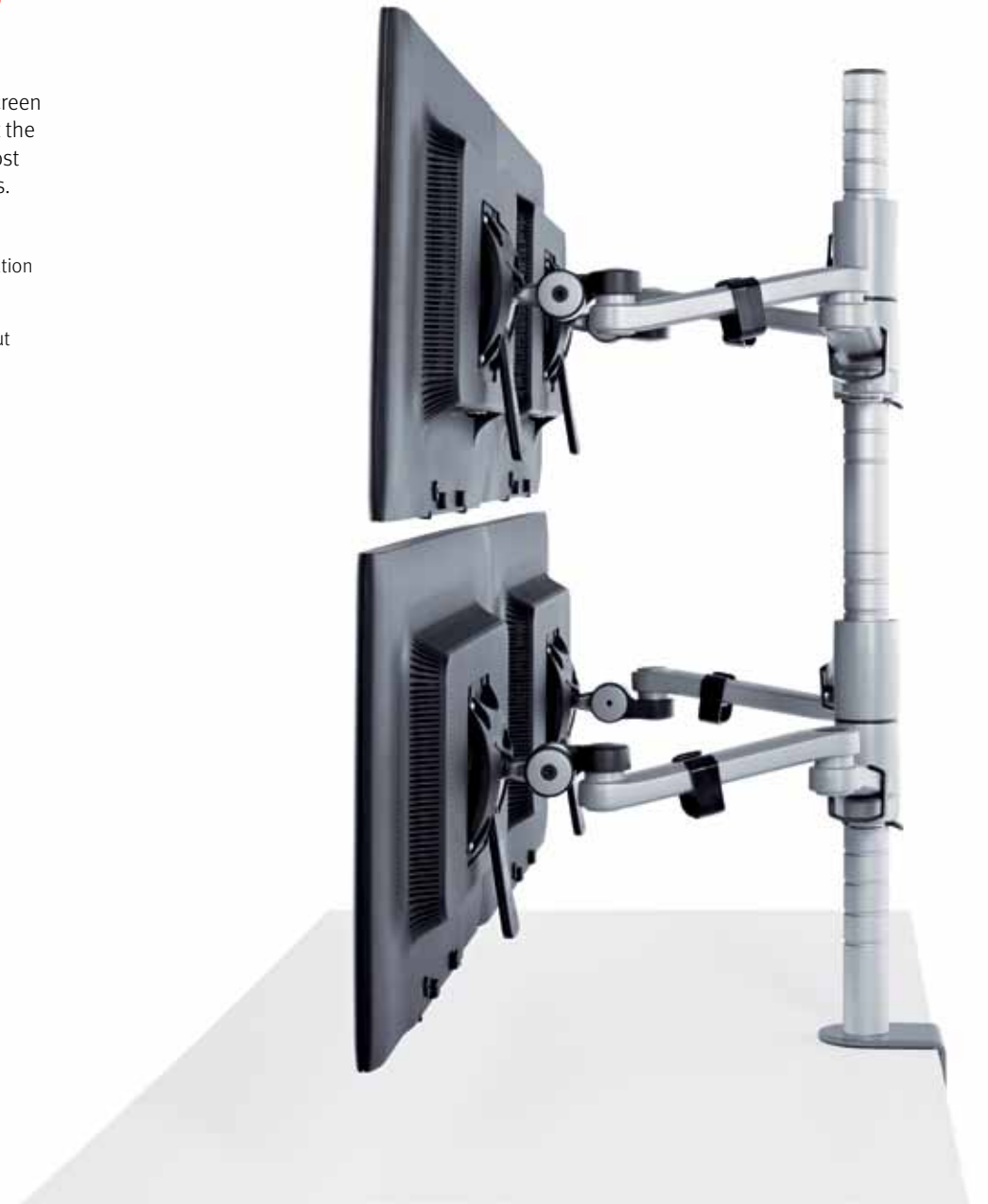

Monitor Configurations

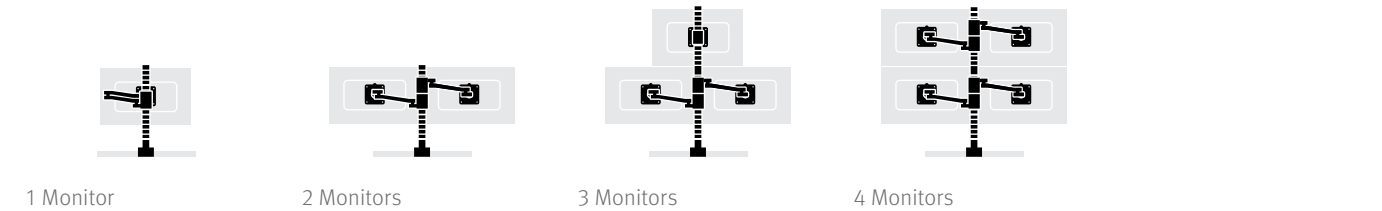
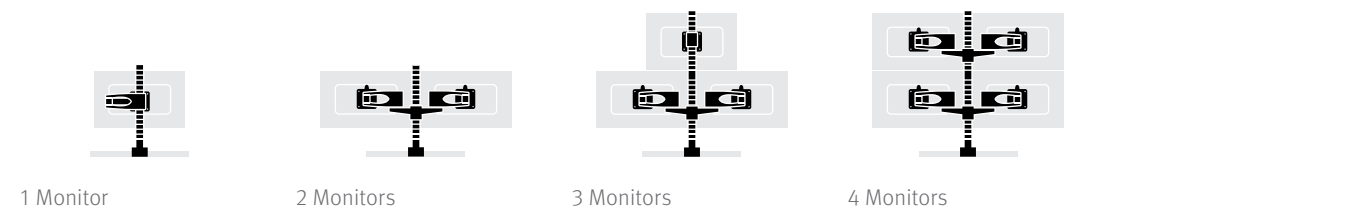

Comparing High-Density Supports

Multiple monitors, multiple configurations, and one simple guide to finding what works for you.



Wishbone



Wishbone Plus



Daisyone

| | | | | |
|-----------------------------------|------------------------|-------------------------|--------------------------|-------------------------|
| User Needs | Single | • | • | • |
| | Dual | • | • | • |
| | Triple | • | • | • |
| | Quad | • | • | • |
| Ergonomic Highlights | Vertical Adjustment | 330mm | 330mm | 432mm |
| | Horizontal Adjustment | 425mm | 438mm | 505mm |
| | Tilt Range | +/- 50° | +/- 50° | +/- 50° |
| | Swivel Range | 180° | 180° | 180° |
| Specs | Maximum Monitor Weight | 26lbs / 11.8kg each | 52lbs each / 23.6kg each | 19lbs each / 8.6kg each |
| | Minimum Monitor Weight | 0lbs | 0lbs | 0lbs |
| | Scalable Solution | • | • | • |
| | Adjustability | Static | Static | Static |
| | Attachments | Monitor/Tablet / Laptop | Monitor/Tablet / Laptop | Monitor/Tablet / Laptop |
| Design for the Environment | Recyclable | 100% | 100% | 97% |
| | Pre-Consumer Content | 32% | 35% | 38% |
| | Post-Consumer Content | 31% | 32% | 34% |
| | GREENGUARD® | • | • | • |

Computer Support

Jaw™

Jaw clamps to the top and bottom of your CPU, holding it securely in place.

Holds up to 25kg and CPUs with range of 90-240mm and a height range of 290-510mm

Designer

Colebrook Bosson Saunders

Warranty

12-years, 24/7



Computer Support

Clam™

Mounted horizontally or vertically, Clam's intuitive design envelops the CPU. Available with lockable option.

Holds up to 25kg and CPUs from 300x560mm (h) to 140x240mm (w) (large) or 250x480mm (h) to 90x140mm (w) (small)

Designer

Colebrook Bosson Saunders

Warranty

12-years, 24/7



Computer Support

Loop™

Lightweight and easy to install, Loop supports your CPU with a strong nylon strap that doesn't call attention to itself.

Holds up to 20kg and CPUs from 240-500mm high to 80-225mm wide

Designer

Colebrook Bosson Saunders

Warranty

12-years, 24/7



Computer Support

ADDB

Free up desktop space by securing your CPU beneath your work surface. Slides out and swivels to access connections.

Holds up to 25kg. 300-500mm height and 105-210mm width.

Designer

CBS

Warranty

12-years, 24/7



Computer Support

ADDB/M

Why just set your CPU on the floor? Place it on casters and roll it out of the way—or right up to you.

Designer

CBS

Warranty

12-years, 24/7



AV Support
AVALL
STANDARD®

The CBS portfolio of AV/VC stands is designed with simplicity and ease of use in mind.

The packaging is designed to provide a simple 'out of the box' solution and all technical jargon is kept to a minimum. One of our key objectives is to make it easy to understand which solution suits the customer requirements most effectively.

How it works for you

Column for cable and AV equipment storage

Low profile base

Lockable castors

Perforated front and lockable back panel

Flat screen mount bracket

Avall Standard can be customised by simply adding the following accessories:

Dual screen kit

VC kit

Blade VC kit

Shelf kit

Cable management kit

Designer

Colebrook Bosson Saunders

Warranty

12-years, 24/7

AVALL Does It All

Safety, organisation, and versatility. What more could you want in large-screen support?



Universal codec mount



Universal camera mount



Lockable hardware



Adjustable shelf

AV Support
VCALL®

CBS VCALL is a cost-effective and minimalist solution to meet your VC requirements in either single or dual screen format.

Simplicity and ease of use is at the heart of the design. It arrives pre-assembled for easy installation and can be used for mobile or static installations.

How it works for you

Single and dual screen configuration

Low profile base with lockable castors

Universal codec mount

Universal camera mount

Customisable front panel for enhanced branding opportunities

Compatible with VC equipment from most of the leading manufacturers including Polycom; Lifesize and Tandberg.

Designer

Colebrook Bosson Saunders

Warranty

12-years, 24/7



DOES YOUR WORK AREA KEEP YOUR MIND IN ORDER?

When there's a place for everything and everything's in its place, it helps your mind stay focused on your work. A personalised work system makes sense of the chaos and clears distractions out of the way. With all your tools conveniently within arm's reach, you can reclaim your thoughts and your valuable desktop space.

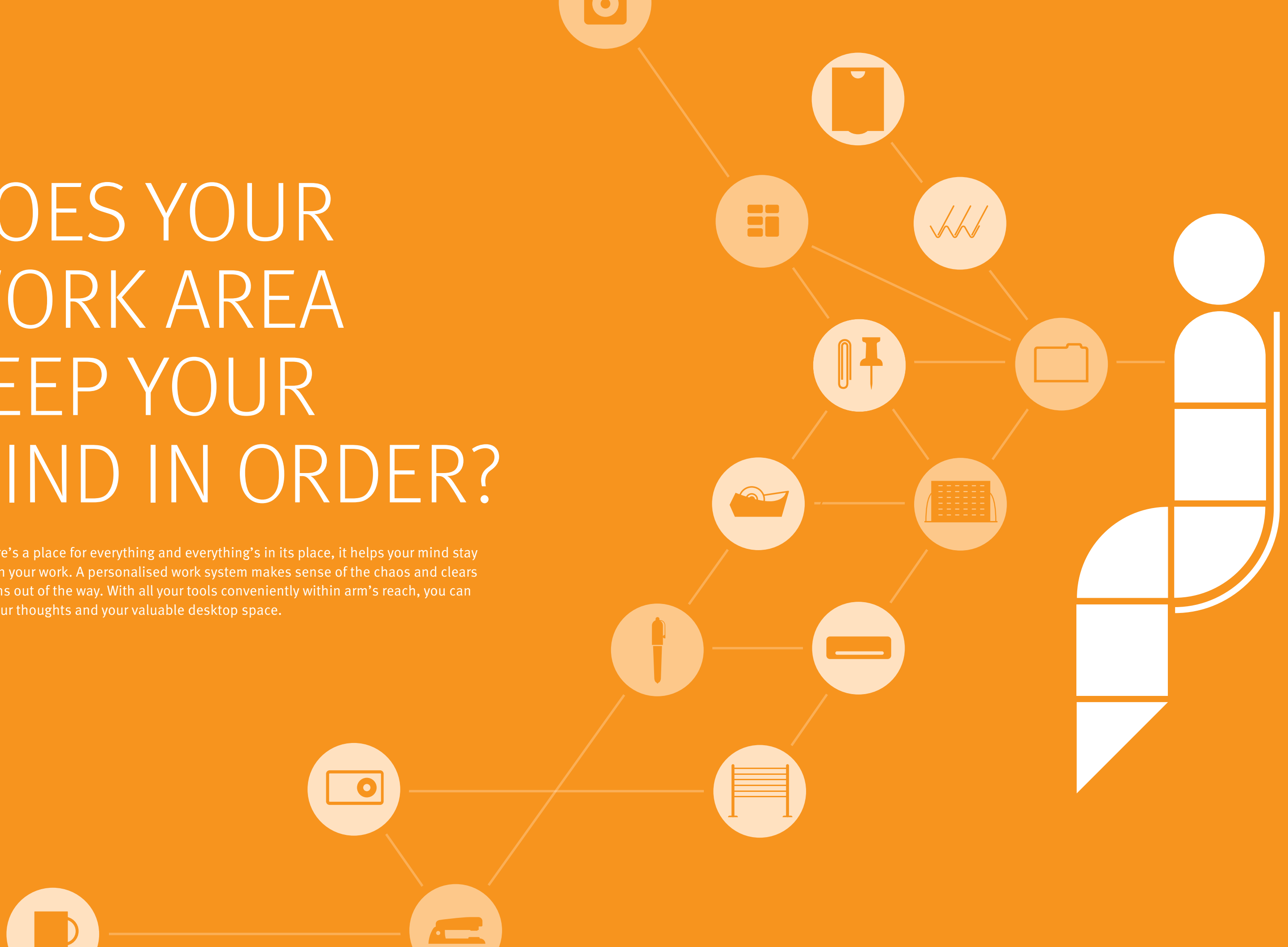

Work Tools

Trays, Storage

Organisational tools keep your area clutter-free and make finding materials you need quick and easy. Available for freestanding or rail-hung applications.

Warranty

12-years, 24/7



Paper Tray

Ideal for hanging on tool rails or screens



Paper Tray (406mm wide)

Comfortably holds oversized documents



Paper Tray (254mm wide)

Organize your in, out, and in progress zones.



Metal Paper Trays

A twin pack of stackable or screen hanging trays



Paper Tray with Lid

A great space for discretely storing private materials



Paper Tray with Lid

A double height space for storing personal items



Organiser Tray

Three compartments for small supplies



Vertical Tray

Keeps binders and folders upright



Binder bin

For vertical storage of files and papers



Double Width Binder Bin

Ideal for your day files and reference materials



Metal Binder Bin

For organising your daily reference materials



Pencil Tray

Always know where your pens and pencils are, and when someone's borrowed them!



CD Rack

Organise your CDs for easy access



Diagonal Tray

Adjusts for right or left handed access



Think Of It as Your 3D Flow Chart

Set up primary and secondary use zones, in and out boxes, or any system that makes sense to you. There's even room for personal items to make you feel at home.

Work Tools
 Holders

Keep the odds and ends of work orderly and out of the way, yet easy to reach. Most options attach to tool rails; some also can be used freestanding.

Warranty
12-years, 24/7



Stackable Mini Shelves
Twin-pack of mini-shelves ideal for stationary and personal items



Whiteboard / Tackable Tablet
Reversible tablet ideal for daily reminders or holding memorabilia



Metal Dividers
Freestanding metal bookends keep reference materials corralled.



Swivel Tray
Attaches to any surface as a great place for all stationary items



Double Width Mini Shelf
Useful rail-mounted shelf to help organise workplace essentials



Sense Surface Attached Toolrail
Provides support for all metal accessories on any worktop



Caddy
Mobile storage and perch seat rolled into one attractive unit, multi configurations available



Umbilical Wire Management
Attaches to any surface providing vertical wire management



Name Plate
Ideal for marking your territory



Surface Attached Tool Rail
Attaches to any square-edge surface providing support for all trays and storage options



Anywhere Case
Ideal support for the agile worker

Ergonomic Solutions Anywhere

At home or in the office, at work or at play, our solutions keep your body relaxed so your brain can do the heavy lifting.



Ergonomic Solutions in the Classroom

Provide flexible spaces that encourage healthy postures and support multiple technology needs.





Ergonomic Solutions in Technology-Rich Environments

Reduce eyestrain, eliminate uncomfortable postures, and clear the work surface with monitor supports.

Good for You. Good for Business, too.

Research shows that ergonomics have a real financial impact, and taking a proactive approach can make a measurable difference in what companies spend on healthcare and workers' compensation each year.

8 of 10

WORKERS
EXPERIENCE BACK
PAIN AT SOME POINT.



Relatively Minor Adjustments

to the entire work space can be significant
in reducing physical stress and injury.

91%

OF ALL COMPUTER USERS SUFFER
FROM EYESTRAIN.

Improving employee well-being

An EU-based company improved productivity
and saved £200,000 in health insurance.
Total savings estimated at £5 million (IOSH).

AT AGE 60, OUR EYES NEED

3 TIMES

AS MUCH LIGHT TO SEE AS THEY
DID AT 20.

3,800,000

WORKING DAYS ARE LOST DUE TO WORK-
RELATED UPPER LIMB OR NECK DISORDERS.

IN THE UK, THE HEALTH EXECUTIVE ESTIMATES THAT MUSCULOSKELETAL DISORDERS,
INCLUDING BACK PAIN, COST UK EMPLOYERS APPROX

£624,000,000

Repetitive Stress Injuries

(RSI) are the fastest growing
occupational hazard.



Herman Miller Ergonomic Solutions

We put a great deal of thought into designing, innovating, and engineering our products—but the products are only part of the equation. At Herman Miller, we also offer something else designed to keep you supported and comfortable: our legendary service.

Herman Miller Dealer Partners

Our network of dealers understand your goals, challenges, and costs and can guide you in designing a solution that supports your body, fits your culture, and uses your furniture to its full potential. Our seasoned dealer teams, project managers, and installation professionals will take care of every detail to ensure the design, specification, financing, delivery, and installation are smooth, on time, and on budget.

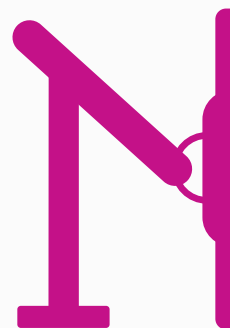

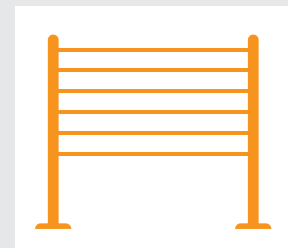
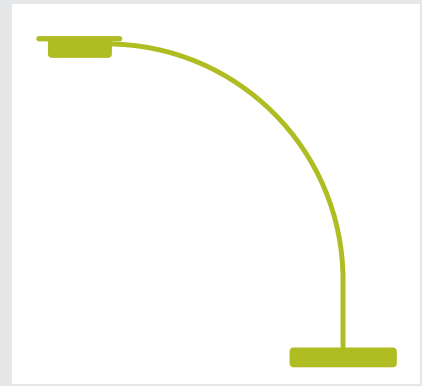
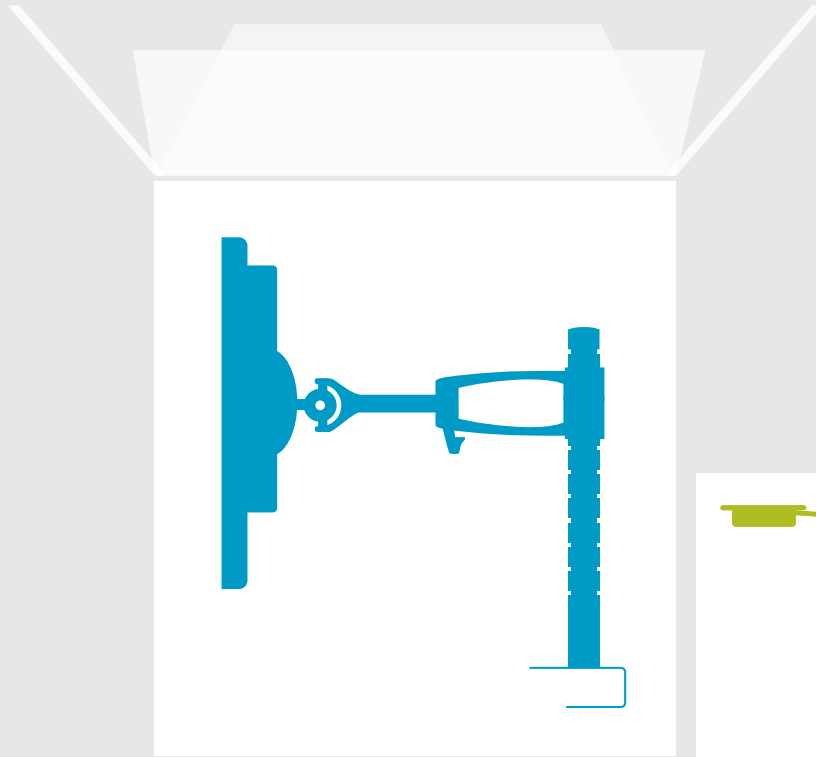

For more information about our products and services or to see a list of dealers, please visit us at: www.hermanmiller.com/worldwide or call +44 845 2267201. © HermanMiller, and  are trademarks of Herman Miller, Inc.

hermanmiller.com/worldwide



PB1865